

REVISIONS			
REV	DESCRIPTION	DATE	BY

HOLE IN P.C.B $\phi 3$
P.C.B THICKNESS 1.6mm

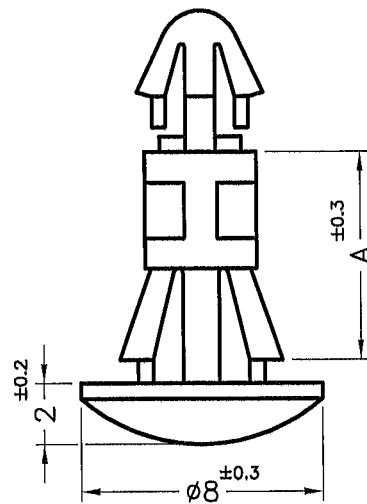
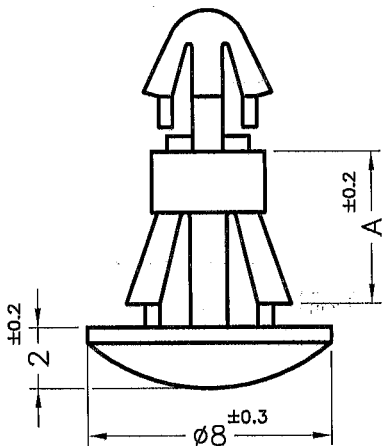
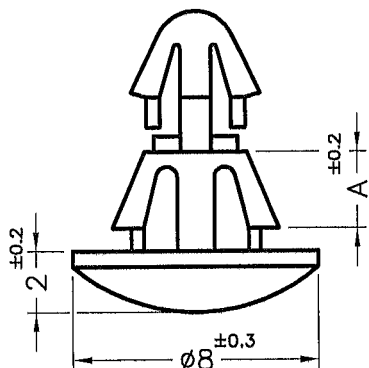

HOLE IN CHASSIS $\phi 4.0$
CHASSIS THICKNESS 0.8~1.6mm

PART NO.	A
RCA-2.5	2.5

PART NO.	A
RCA-3	3.2
RCA-4	4.0
RCA-4.5	4.5
RCA-5	5.0
RCA-5.5	5.5 ^{±0.3}

PART NO.	A
RCA-6	6.0
RCA-6.4	6.4
RCA-7	7.0
RCA-7.5	7.5
RCA-8	8.0
RCA-9	9.0
RCA-9.5	9.5
RCA-10	10.0
RCA-11.1	11.1
RCA-12	12.0
RCA-12.7	12.7
RCA-14	14.0
RCA-16	16.0

NOTE: 1. SHRINKING IS NORMAL STATUS.
內縮為正常現象。
2. MADE OF EQUIVALENT MATERIAL.
均可使用同等材質。



				TITLE SPACER SUPPORT		SPEC. DWG.	
				MATERIAL NYLON 66 UL94V-2		DATE 1999.02.11	
PART NUMBER SEE ABOVE				DRAWING NUMBER RCA-H		DRAWN AMY	
SIZE A4				SCALE 4:1		CHECK 	
UNIT mm				REV B		APPROVED <i>Kang</i>	
COLOR NATURAL				FINISH		TOLERANCE UNLESS OTHERWISE SPECIFIED SEE ABOVE	