

USER MANUAL

HYBRID SOLAR INVERTER/CHARGER

3.5KVA / 5.5KVA 230Vac



Table Of Contents

1.ABOUT THIS MANUAL	1
1.1Purpose.....	1
1.2Scope.....	1
2.SAFETY INSTRUCTIONS	1
3.INTRODUCTION	1
3.1Features.....	2
3.2Basic System Architecture.....	2
3.3Product Overview.....	3
4.INSTALLATION	4
4.1 Unpacking and Inspection.....	4
4.2Unpacking and Inspection.....	4
4.3Preparation.....	4
4.4Mounting the Unit.....	5
4.5Battery Connection.....	6
4.6AC Input/Output Connection.....	8
4.7PV Connection.....	9
4.8Final Assembly.....	10
5.OPERATION	10
5.1Power ON/OFF.....	10
5.2 Operation and Display Panel.....	10
5.3 LCD Display Icons.....	11
5.4 LCD Setting.....	13
5.5 Display Setting.....	20
5.6 Operating Mode Description.....	23
5.7 Fault Reference Code.....	24
5.8 Warning Indicator.....	25
6. CLEARANCE AND MAINTENANCE FOR ANTI-DUST KIT	26
6.1 Overview.....	26
6.2 Clearance and Maintenance.....	26
7. BATTERY EQUALIZATION DESCRIPTION	27
7.1 How to Apply Equalization Function.....	27
7.2 When to Equalize.....	27
7.3 Equalize charging time and timeout.....	27
8. SETTING FOR LITHIUM BATTERY	28
8.1 Lithium Battery Connection.....	28
8.2 Battery communication cable port definition.....	28
8.3 LCD setting.....	29
8.4 LCD Display.....	29
9. SPECIFICATIONS	30
9.1 Table 1 Line Mode Specifications.....	30
9.2 Table 2 Inverter Mode Specifications.....	31
9.3 Table 3 Charge Mode Specifications.....	32
9.4 Table 4 General Specifications.....	32
10. TROUBLE SHOOTING	33
11. PARALLEL INSTALLATION GUIDE	34
11.1 Instruction.....	34
11.2 Package Contents.....	34
11.3 Mounting the Unit.....	34
11.4 Wiring Connection.....	35
12. PARALLEL OPERATION IN SINGLE PHASE	36
12.1 Two inverters in parallel.....	36
12.2 Three-phase Parallel Operation Cable Connection.....	40
12.3 PV Connection.....	42
13. GENERAL SPECIFICATIONS	43

1.About this manual

1.1Purpose

This manual describes the assembly, installation, operation and troubleshooting of this unit. Please read this manual carefully before installations and operations. Keep this manual for future reference.

1.2Scope

This manual provides safety and installation guidelines as well as information on tools and wiring.

2.SAFETY INSTRUCTIONS



WARNING: This chapter contains important safety and operating instructions. Read and keep this manual for future reference.

- 1.Before using the unit, read all instructions and cautionary markings on the unit, the batteries and all appropriate sections of this manual.
- 2.CAUTION --To reduce risk of injury, charge only deep-cycle lead acid type rechargeable batteries. Other types of batteries may burst, causing personal injury and damage.
- 3.Do not disassemble the unit. Take it to a qualified service center when service or repair is required. Incorrect re-assembly may result in a risk of electric shock or fire.
- 4.To reduce risk of electric shock, disconnect all wirings before attempting any maintenance or cleaning.Turning off the unit will not reduce this risk.
- 5.CAUTION – Only qualified personnel can install this device with battery.
- 6.NEVER charge a frozen battery.
- 7.For optimum operation of this inverter/charger, please follow required spec to select appropriate cable size. It's very important to correctly operate this inverter/charger.
- 8.Be very cautious when working with metal tools on or around batteries.
A potential risk exists to drop a tool to spark or short circuit batteries or other electrical parts and could cause an explosion.
- 9.Please strictly follow installation procedure when you want to disconnect AC or DC terminals. Please refer to INSTALLATION section of this manual for the details.
- 10.Fuse is provided as over-current protection for the battery supply.
- 11.GROUNDING INSTRUCTIONS -This inverter/charger should be connected to a permanent grounded wiring system. Be sure to comply with local requirements and regulation to install this inverter.
- 12.NEVER cause AC output and DC input short circuited.
Do NOT connect to the mains when DC input short circuits.
- 13.Warning!! Only qualified service persons are able to service this device.
If errors still persist after following troubleshooting table,
please send this inverter/charger back to local dealer or service center for maintenance.

3. INTRODUCTION

This is a multi-function inverter/charger, combining functions of inverter, MPPT solar charger and battery charger to offer uninterrupted power support with portable size. Its comprehensive LCD display offers user-configurable and easy-accessible button operation such as battery charging current, AC/solar charger priority, and acceptable input voltage based on different applications.

3.1 Features

- ▶ Pure sine wave inverter
- ▶ Inverter running without battery
- ▶ Built-in MPPT solar controller
- ▶ Configurable input voltage range for home appliances and personal computers via LCD setting
- ▶ Configurable battery charging current based on applications via LCD setting
- ▶ Configurable AC/Solar Charger priority via LCD setting
- ▶ Compatible to mains voltage or generator power
- ▶ Auto restart while AC is recovering
- ▶ Overload/ Over temperature/ short circuit protection
- ▶ Smart battery charger design for optimized battery performance
- ▶ Cold start function

3.2 Basic System Architecture

The following illustration shows basic application for this inverter/charger.

It also includes following devices to have a complete running system:

- ▶ Generator or Utility.
- ▶ PV modules (option)

Consult with your system integrator for other possible system architectures depending on your requirements.

This inverter can power all kinds of appliances in home or office environment, including motor-type appliances such as tube light, fan, refrigerator and air conditioner.

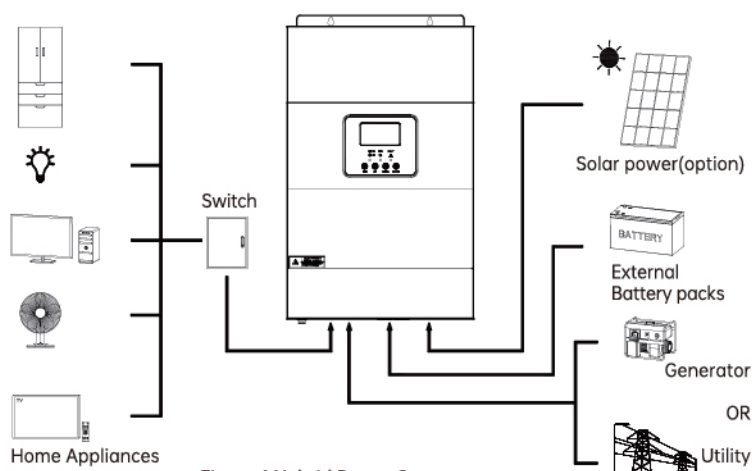
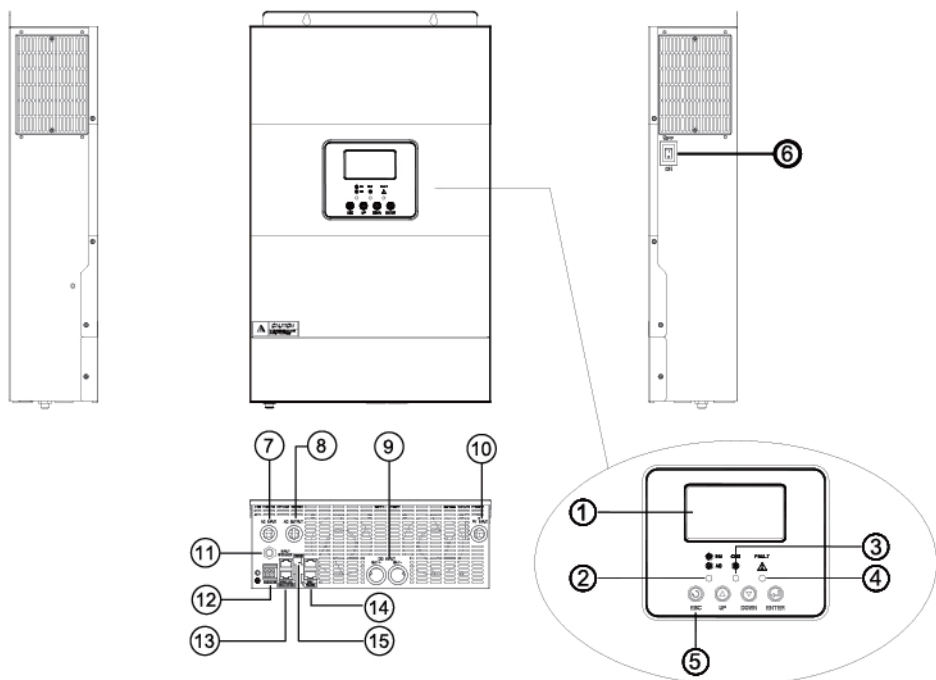

Figure 1 Hybrid Power System

3.3 Product Overview



- | | |
|-----------------------|---|
| 1.LCD display | |
| 2.Status indicator | |
| 3.Charging indicator | |
| 4.Fault indicator | |
| 5.Function buttons | |
| 6.Power on/off switch | |
| 7.AC input | |
| 8.AC output | |
| 9.Battery input | |
| 10.PV input | |
| | 11. Circuit breaker |
| | 12. Dry contact (Optional) |
| | 13. Parallel communication port (only parallel) |
| | 14. BMS communication port (only parallel) |
| | 15. RS232 communication port |

NOTE:

For parallel model installation and operation, please check the parallel installation guide for the details.

4. INSTALLATION

4.1 Unpacking and Inspection

Before installation, please inspect the unit.

Be sure that nothing inside the package is damaged.

You should have received the following items inside of package:

- ▶ The unit x 1 Parallel wire (only parallel) x 1
- ▶ User manual x 1 Current equalization wire (parallel only) x 1

4.2 Preparation

Before connecting all wirings, please take off bottom cover by removing two screws as shown below.

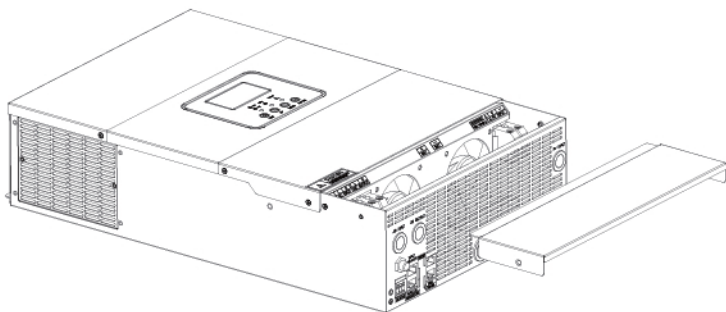

4.3 Mounting the Unit

Consider the following points before selecting where to install:

- ▶ Do not mount the inverter on flammable construction materials.
- ▶ Mount on a solid surface
- ▶ Install this inverter at eye level in order to allow the LCD display to be read at all times.
- ▶ The ambient temperature should be between 0°C and 55°C to ensure optimal operation.
- ▶ The recommended installation position is to be adhered to the wall vertically.
- ▶ Be sure to keep other objects and surfaces as shown in the right diagram to guarantee sufficient heat dissipation and to have enough space for removing wires.

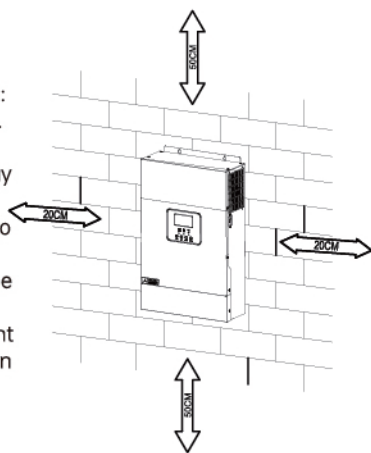

SUITABLE FOR MOUNTING ON CONCRETE OR OTHER NON-COMBUSTIBLE SURFACE ONLY.

Install the unit by screwing three screws. It's recommended to use M4 or M5 screws.

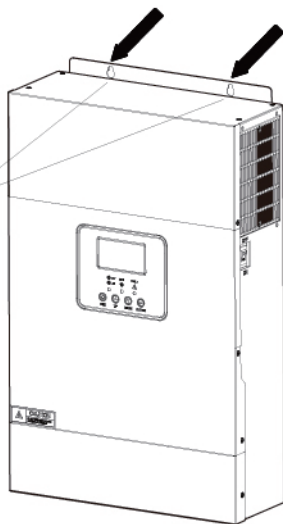

4.4 Battery Connection

CAUTION:

For safety operation and regulation compliance, it's requested to install a separate DC over-current protector or disconnect device between battery and inverter. It may not be requested to have a disconnect device in some applications, however, it's still requested to have over-current protection installed. Please refer to typical amperage in below table as required fuse or breaker size.

WARNING! It's very important for system safety and efficient operation to

WARNING! Use appropriate cable for battery connection.

To reduce risk of injury, please use the proper recommended cable , stripping length(L2) and tinning length(L1) as below.

STRIPPING LENGTH:

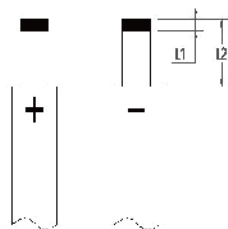

Recommended battery cable , stripping length(L2)and tinning length(L1):

Model	Maximum Amperage	Battery capacity	Wire Size	Cable mm ²	L1 (mm)	L 2 (mm)	Torque value
3.5KVA	137A	100AH	2AWG	38	3	18	2~ 3 Nm
5.5KVA	137A	200AH	2AWG	38	3	18	2~ 3 Nm

Please follow below steps to implement battery connection:

- 1.Remove insulation sleeve 18 mm for positive and negative cables based on recommended stripping length.
- 2.Connect all battery packs as units requires. It's suggested to use recommended battery capacity.
- 3.Insert battery cable flatly into battery connector of inverter and make sure the bolts are tightened with torque of 2-3 Nm. Make sure polarity at both the battery and the inverter/charge is correctly connected and battery cables are tightly screwed to the battery connector.

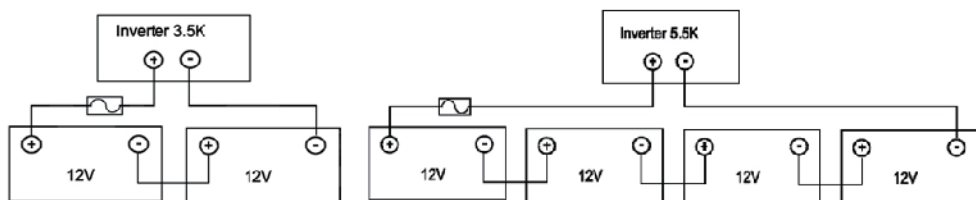
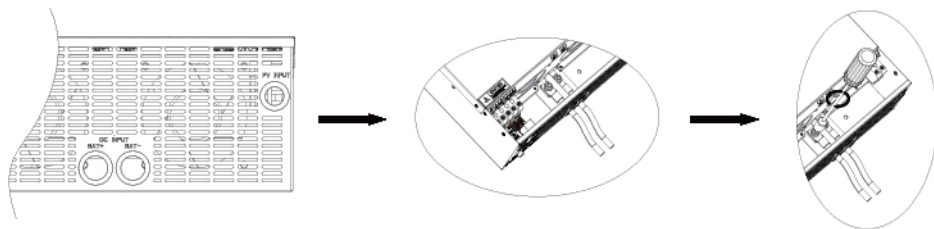

WARNING: Shock Hazard

Installation must be performed with care due to high battery voltage in series.



CAUTION!! Do not place anything between the flat part of the inverter terminal otherwise, overheating may occur.

CAUTION!! Do not apply anti-oxidant substance on the terminals before terminals are connected tightly.

CAUTION!! Before making the final DC connection or closing DC breaker/disconnector, be sure positive (+) must be connected to positive (+) and negative (-) must be connected to negative (-).

4.5 AC Input/Output Connection

CAUTION!! Before connecting to AC input power source, please install a separate AC breaker between inverter and AC input power source. This will ensure the inverter can be securely disconnected during maintenance and fully protected from over current of AC input. The recommended spec of AC breaker is 50A

CAUTION!! There are two terminal blocks with "IN" and "OUT" markings. Please do NOT mis-connect input and output connectors.

WARNING! All wiring must be performed by a qualified personnel.

WARNING! It's very important for system safety and efficient operation to use appropriate cable for AC input connection. To reduce risk of injury, please use the proper recommended cable size as below.

Suggested cable requirement for AC wires

Model	Gauge	Torque Value
3.5KVA	10AWG	1.4~ 1.6Nm
5.5KVA	8AWG	1.4~ 1.6Nm

Please follow below steps to implement AC input/output connection:

1. Before making AC input/output connection, be sure to open DC protector or disconnecter first.
2. Remove insulation sleeve 10mm for six conductors. And shorten phase L and neutral conductor N 3mm.
3. Insert AC input wires according to polarities indicated on terminal block and tighten the terminal screws. Be sure to connect PE protective conductor (⊕) first.

⊕ → Ground (yellow-green) L → LINE (brown or black) N → Neutral (blue)

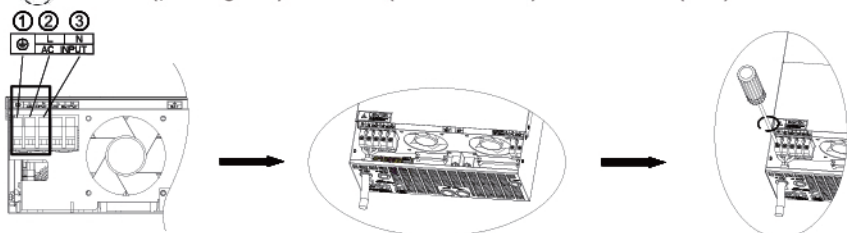

WARNING:

Be sure that AC power source is disconnected before attempting to hardwire it to the unit.

4. Then, insert AC output wires according to polarities indicated on terminal block and tighten terminal screws. Be sure to connect PE protective conductor (⊕) first.

⊕ → Ground (yellow-green) L → LINE (brown or black) N → Neutral (blue)

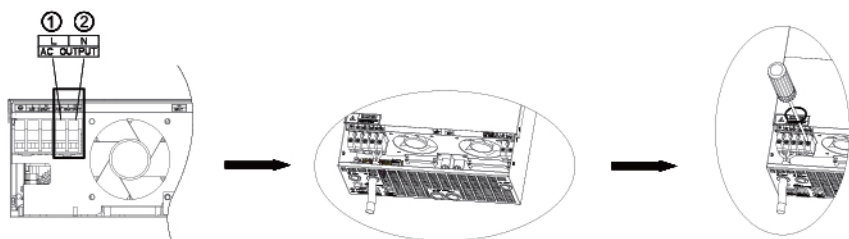

WARNING:

Be sure that AC power source is disconnected before attempting to hardwire it to the unit.

- Note: Important**
- ▶ When the inverter is working in battery mode or standby mode, neutral of output is connected to grounding of AC output.
 - ▶ When the inverter is working in AC mode, neutral of output is disconnected to grounding of AC output and connected to neutral of AC input.

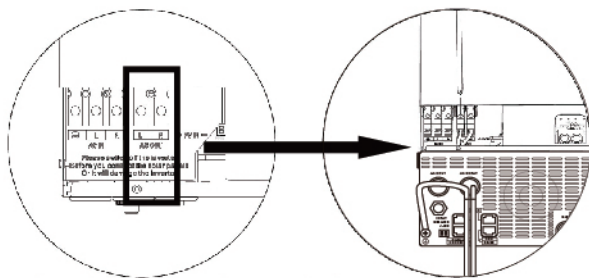

5. Make sure the wires are securely connected.

CAUTION: Important

Be sure to connect AC wires with correct polarity. If L and N wires are connected reversely, it may cause utility short-circuited when these inverters are worked in parallel operation.

CAUTION: Appliances such as air conditioner are required at least 2~3 minutes to restart because it's required to have enough time to balance refrigerant gas inside of circuits. If a power shortage occurs and recovers in a short time, it will cause damage to your connected appliances. To prevent this kind of damage, please check manufacturer of air conditioner if it's equipped with time-delay function before installation. Otherwise, this inverter/charger will trig overload fault and cut off output to protect your appliance but sometimes it still causes internal damage to the air conditioner.

4.6 PV CONNECTION

CAUTION: Before connecting to PV modules, please install separately a DC circuit breaker between inverter and PV modules.

WARNING! All wiring must be performed by a qualified personnel.

WARNING! It's very important for system safety and efficient operation to use appropriate cable for PV module connection. To reduce risk of injury, please use the proper recommended cable size as below.

Model	Typical Amperage	Cable Size	Torque
3.5KVA	15A	12 AWG	1.4~1.6 Nm
5.5KVA	18A	12 AWG	1.4~1.6 Nm

PV Module Selection:

When selecting proper PV modules, please be sure to consider below parameters:

1. Open circuit Voltage (Voc) of PV modules not exceeds max. PV array open circuit voltage of inverter.
2. Open circuit Voltage (Voc) of PV modules should be higher than min. battery voltage.

Solar Charging Mode	
Inverter model	3.5KVA / 5.5KVA
Max. PV Array Open Circuit Voltage	500DC
PV Array MPPT Voltage Range	120VDC~450VDC

Take the 330Wp PV module as an example. After considering above two parameters, the recommended module configurations are listed in the table below.

Solar Panel Spec. (reference)	SOLAR INPUT	Q'ty of panels	Total input power	Inverter Model
- 330Wp	Min in serial: 6 pcs, max. in serial: 12 pcs			
- Vmp: 33.25Vdc	6 pcs in serial	6 pcs	1980W	3.5KVA/5.5KVA
- Imp: 9.925A	10 pcs in serial	10 pcs	3300W	3.5KVA/5.5KVA
- Voc: 40.35Vdc	12 pcs in serial	12 pcs	3960W	3.5KVA/5.5KVA
- Isc: 10.79A	6 pieces in serial and 2 sets in parallel	12 pcs	3960W	3.5KVA/5.5KVA
Cells: 60	8 pieces in serial and 2 sets in parallel	16 pcs	5280W	5.5KVA

PV Module Wire Connection:

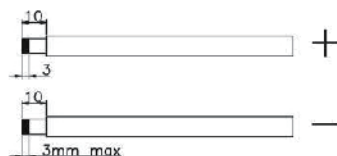

Please follow below steps to implement PV module connection:

- 1.Remove insulation sleeve 10 mm for positive and negative conductors
- 2.Check correct polarity of connection cable from PV modules and PV input connectors.
Then, connect positive pole (+) of connection cable to positive pole (+) of PV input connector.
Connect negative pole (-) of connection cable to negative pole (-) of PV input connector.

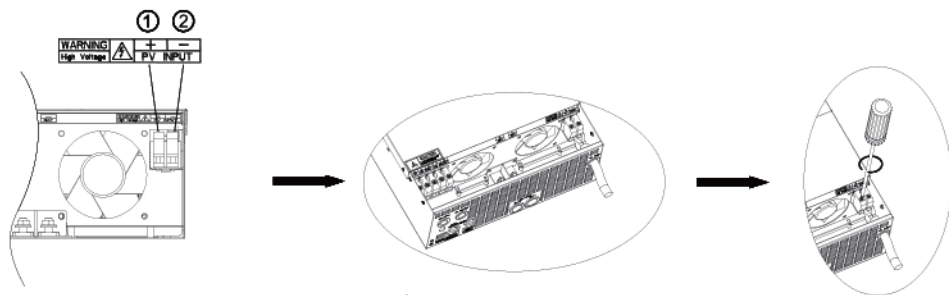

- 3.Make sure the wires are securely connected.

4.7 FINAL ASSEMBLY

After connecting all wirings, please put bottom cover back by screwing two screws as shown below.

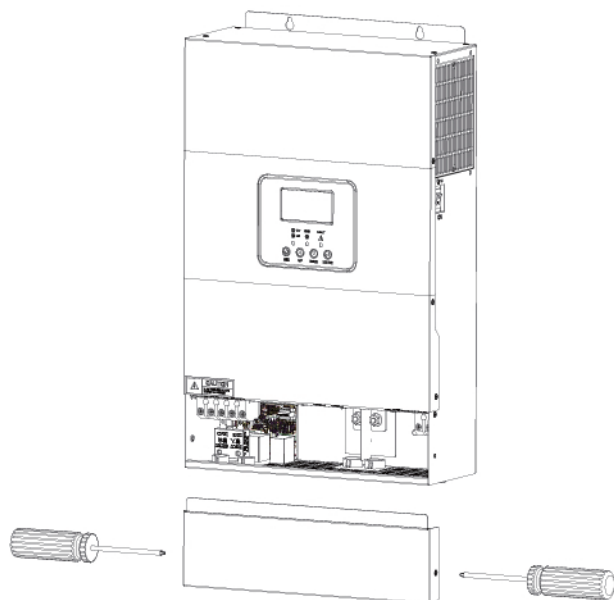

4.8 Dry Contact Signal

There is one dry contact (3A/250VAC) available on the rear panel.

It could be used to deliver signal to external device when battery voltage reaches warning level.

Unit Status	Condition		Dry contact port:		
			NC & C	NO & C	
Power Off	Unit is off and no output is powered.		Close	Open	
Power On	Output is powered from Utility.		Close	Open	
	Output is powered from Battery or Solar.	Program 01 set as Utility	Battery voltage < Low DC warning voltage	Open	Close
			Battery voltage > Setting value in Program 13 or battery charging reaches floating stage	Close	Open
	Output is powered from Battery or Solar.	Program 01 is set as SBU or SUB or Solar first	Battery voltage < Setting value in Program 12	Open	Close
Battery voltage > Setting value in Program 13 or battery charging reaches floating stage			Close	Open	

5. Equipment operation

5.1 Operation Power ON/OFF

Once the unit has been properly installed and the batteries are connected well, simply press On/Off switch (located on the button of the case) to turn on the unit.

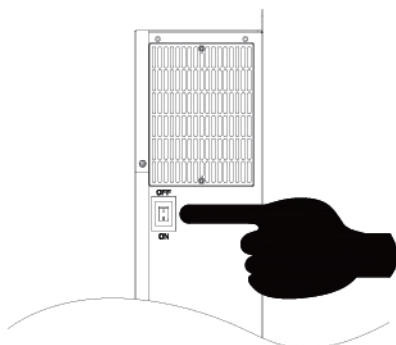



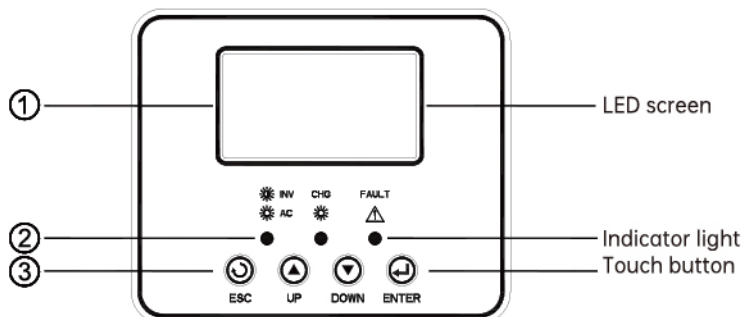

5.2 Operation and Display Panel

The operation and display panel, shown in below chart, is on the front panel of the inverter. It includes three indicators, four function keys and a LCD display, indicating the operating status and input/output power information.



LED Indicator





LED Indicator		Messages	
 AC /  INV	Green	Solid On	Output is powered by utility in Line mode.
		Flashing	Output is powered by battery or PV in battery mode.
 CHG	Green	Solid On	Battery is fully charged.
		Flashing	Battery is charging.
 FAULT	Red	Solid On	Fault occurs in the inverter.
		Flashing	Warning condition occurs in the inverter.



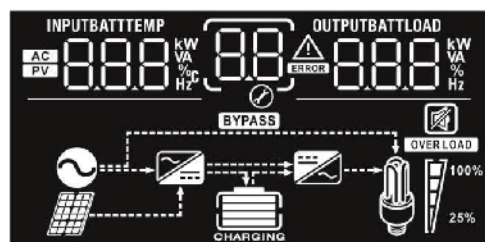















Function Keys

Function Key	Description
ESC	To exit setting mode
UP	To go to previous selection
DOWN	To go to next selection
ENTER	To confirm the selection in setting mode or enter setting mode

5.3 LCD Display Icons



Icon	Function description
Input Source Information	
 AC	Indicates the AC input.
 PV	Indicates the PV input
 INPUTBATTEMP  OUTPUTBATTLOAD	Indicate input voltage, input frequency, PV voltage, battery voltage and charger current.

Icon	Function description			
Configuration Program and Fault Information				
	Indicates the setting programs.			
	Indicates the warning and fault codes. Warning:  flashing with warning code. Fault:  lighting with fault code			
Output Information				
	Indicate output voltage, output frequency, load percent, load in VA, load in Watt and discharging current.			
Battery Information				
	Indicates battery level by 0-24%, 25-49%, 50-74% and 75-100% in battery mode and charging status in line mode.			
Load Information				
	Indicates overload.			
	Indicates the load level by 0-24%, 25-49%, 50-74% and 75-100%.			
	0%~24%	25%~49%	50%~74%	75%~100%
				
Mode Operation Information				
	Indicates unit connects to the mains.			
	Indicates unit connects to the PV panel.			
	Indicates load is supplied by utility power.			
	Indicates the utility charger circuit is working.			
	Indicates the DC/AC inverter circuit is working.			
Mute Operation				
	Indicates unit alarm is disabled.			

5.4 LCD Setting

After pressing and holding ENTER button for 3 seconds, the unit will enter setting mode. Press "UP" or "DOWN" button to select setting programs. And then, press "ENTER" button to confirm the selection or ESC button to exit.

Setting Programs:

Program	Description	Selectable option	
00	Exit setting mode	Escape 00 ESC	
01	Output source priority: To configure load power source priority	Utility first (default) 01 UTI	Utility will provide power to the loads as first priority. Solar and battery energy will provide power to the loads only when utility power is not available.
		Solar first 01 SOL	Solar energy provides power to the loads as first priority. If solar energy is not sufficient to power all connected loads, solar energy and utility will supply power to the loads at the same time. Battery provides power to the loads only when any one condition happens: -Solar energy and utility not available -Solar energy is weak and utility is not available.
		SBU priority 01 SBU	Solar energy provides power to the loads as first priority. If solar energy is not sufficient to power all connected loads, battery energy will supply power to the loads at the same time. Utility provides power to the loads only when battery voltage drops to either low-level warning voltage or the setting point in program 12.
02	Maximum charging current: To configure total charging current for solar and utility chargers. (Max. charging current = utility charging current + solar charging current)	10A 02 10 A	20A 02 20 A
		30A 02 30 A	40A 02 40 A
		50A 02 50 A	60A (default) 02 60 A

		70A 02 70 ^A ⊗	80A 02 80 ^A ⊗
		90A 02 90 ^A ⊗	100A 02 100 ^A ⊗
03	AC input voltage range	Appliances (default) 03 APL ⊗	If selected, acceptable AC input voltage range will be 90-280VAC.
		UPS 03 UPS ⊗	If selected, acceptable AC input voltage range will be 170-280VAC.
05	Battery type	AGM (default) 05 AGM ⊗	Flooded 05 FLd ⊗
		User-Defined 05 LIB ⊗	05 USE ⊗
		If "User-Defined" is selected, battery charge voltage and low DC cut-off voltage can be set up in program 26, 27 and 29.	
06	Auto restart when overload occurs	Restart disable (default) 06 Lfd ⊗	Restart enable 06 LfE ⊗
		Restart disable (default) 07 Lfd ⊗	Restart enable 07 LfE ⊗
07	Auto restart when over temperature occurs	Restart disable (default) 07 Lfd ⊗	Restart enable 07 LfE ⊗
09	Output frequency	50Hz (default) 09 50 ^{Hz} ⊗	60Hz 09 60 ^{Hz} ⊗
10	Output voltage	220V 10 220 ^v ⊗	230V (default) 10 230 ^v ⊗
		240V 10 240 ^v ⊗	
11	Maximum utility charging current Note: If setting value in program 02 is smaller than that in program in 11, the inverter will apply charging current from program 02 for utility charger.	2A 11 2A ⊗	10A 11 10A ⊗
		20A 11 20A ⊗	30A (default) 11 30A ⊗
		40A 11 40A ⊗	50A 11 50A ⊗
		60A 11 60A ⊗	

12	Setting voltage point back to utility source when selecting "SBU priority" or "Solar first" in program 01.	Available options in 3.5KW model:	
		22.0V 12 ^{BATT} 220 ^v ⊗	22.5V 12 ^{BATT} 225 ^v ⊗
		23.0V (default) 12 ^{BATT} 230 ^v ⊗	23.5V 12 ^{BATT} 235 ^v ⊗
		24.0V 12 ^{BATT} 240 ^v ⊗	24.5V 12 ^{BATT} 245 ^v ⊗
		25.0V 12 ^{BATT} 250 ^v ⊗	25.5V 12 ^{BATT} 255 ^v ⊗
		Available options in 5.5KW model:	
		44V 12 ^{BATT} 44 ^v ⊗	45V 12 ^{BATT} 45 ^v ⊗
		46V (default) 12 ^{BATT} 46 ^v ⊗	47V 12 ^{BATT} 47 ^v ⊗
		48V 12 ^{BATT} 48 ^v ⊗	49V 12 ^{BATT} 49 ^v ⊗
		50V 12 ^{BATT} 50 ^v ⊗	51V 12 ^{BATT} 51 ^v ⊗
13	Setting voltage point back to battery mode when selecting "SBU priority" or "Solar first" in program 01.	Available options in 3.5KW model:	
		Battery fully charged 13 ^{BATT} FUL ⊗	24V 13 ^{BATT} 240 ^v ⊗
		24.5V 13 ^{BATT} 245 ^v ⊗	25V 13 ^{BATT} 250 ^v ⊗
		25.5V 13 ^{BATT} 255 ^v ⊗	26V 13 ^{BATT} 260 ^v ⊗
		26.5V 13 ^{BATT} 265 ^v ⊗	27V (default) 13 ^{BATT} 270 ^v ⊗
		27.5V 13 ^{BATT} 275 ^v ⊗	28V 13 ^{BATT} 280 ^v ⊗

		28.5V 13 ^{BATT} 285 v	29V 13 ^{BATT} 290 v
		Available options in 5.5KW model:	
		Battery fully charged 13 ^{BATT} FUL	48V 13 ^{BATT} 480 v
		49V 13 ^{BATT} 490 v	50V 13 ^{BATT} 500 v
		51V 13 ^{BATT} 510 v	52V 13 ^{BATT} 520 v
		53V 13 ^{BATT} 530 v	54V (default) 13 ^{BATT} 540 v
		55V 13 ^{BATT} 550 v	56V 13 ^{BATT} 560 v
		57V 13 ^{BATT} 570 v	58V 13 ^{BATT} 580 v
16	Charger source priority: To configure charger source priority	If this inverter/charger is working in Line, Standby or Fault mode, charger source can be programmed as below:	
		Utility first 16 [⊗] CUT	Utility will charge battery as first priority. Solar energy will charge battery only when utility power is not available.
		Solar first 16 [⊗] CSO	Solar energy will charge battery as first priority. Utility will charge battery only when solar energy is not available.
		Solar and Utility (default) 16 [⊗] SNU	Solar energy and utility will charge battery at the same time.
		Only Solar 16 [⊗] OSO	Solar energy will be the only charger source no matter utility is available or not.
		If this inverter/charger is working in Battery mode, only solar energy can charge battery. Solar energy will charge battery if it's available and sufficient.	
18	Alarm control	Alarm on (default) 18 [⊗] 60N	Alarm off 18 [⊗] 60F

19	Auto return to default display screen	Return to default display screen (default)	If selected, no matter how users switch display screen, it will automatically return to default display screen (Input voltage/output voltage) after no button is pressed for 1 minute.
		Stay at latest screen	If selected, the display screen will stay at latest screen user finally switches.
20	Backlight control	Backlight on (default)	Backlight off
22	Beeps while primary source is interrupted	Alarm on (default)	Alarm off
23	Overload bypass: When enabled, the unit will transfer to line mode if overload occurs in battery mode.	Bypass disable (default)	Bypass enable
25	Record Fault code	Record enable (default)	Record disable
26	Bulk charging voltage (C.V voltage)	3.5KW default setting: 28.2V	
		5.5KW default setting: 56.4V	
		If self-defined is selected in program 5, this program can be set up. Setting range is from 25.0V to 31.5V for 3.5KW model and 48.0V to 61.0V for 5.5KW model. Increment of each click is 0.1V.	
27	Floating charging voltage	3.5KW default setting: 27.0V	
		5.5KW default setting: 54.0V	
		If self-defined is selected in program 5, this program can be set up. Setting range is from 25.0V to 31.5V for 3.5KW model and 48.0V to 61.0V for 5.5KW model. Increment of each click is 0.1V. If "USE" is selected in program 05, this program can be set up.	



28	AC output mode	Single: This inverter is used in single phase application. 28 510	Parallel: This inverter is operated in parallel system. (Need hardware support) 28 PARL
		L1 phase 28 3P1	The inverter is operated in L1 phase in 3-phase application.
		L2 phase 28 3P2	The inverter is operated in L2 phase in 3-phase application.
		L3 phase 28 3P3	The inverter is operated in L3 phase.in 3-phase application.
29	Low DC cut-off voltage	3.5KW default setting: 21.0V C04 29 21.0 ^{BATT} v	
		5.5KW default setting: 42.0V C04 29 42.0 ^{BATT} v	
		If self-defined or lithium battery is selected in program 5, this program can be set up. Setting range is from 21.0V to 24.0V for 3.5KW model and 42.0V to 48.0V for 5.5KW model. Increment of each click is 0.1V. Low DC cut-off voltage will be fixed to setting value no matter what percentage of load is connected.	
30	Battery equalization	Battery equalization 30 EEN	Battery equalization disable (default) 30 EdS
		If "Flooded" or "User-Defined" is selected in program 05, this program can be set up.	
31	Battery equalization voltage	3.5KW default setting: 29.2V EU 31 29.2 ^{BATT} v	
		5.5KW default setting: 58.4V EU 31 58.4 ^{BATT} v	
		Setting range is from 25.0V to 31.5V for 3.5KW model and 48.0V to 61.0V for 5.5KW model. Increment of each click is 0.1V.	
33	Battery equalized time	60 mins (default) 33 60	Setting range is from 5 mins to 900 mins. Increment of each click is 5 mins.
34	Battery equalized timeout	120 mins (default) 34 120	Setting range is from 5 mins to 900 mins. Increment of each click is 5 mins.



35	Equalization interval	30 days (default) 35 30d	Setting range is from 0 to 90 days. Increment of each click is 1 day
36	Equalization activated immediately	Enable 36 AEN	Disable (default) 36 ADS
		If equalization function is enabled in program 30, this program can be set up. If "Enable" is selected in this program, it's to activate battery equalization immediately and LCD main page will shows "EQ" If "Disable" is selected, it will cancel equalization function until next activated equalization time arrives based on program 35 setting. At this time, "EQ" will not be shown in LCD main page.	
37	Communication protocol	37 PLY 37 F1E 37 Jdb	
		If Lithium battery is selected in program 5, the corrected protocol should be selected to establish the communication between the inverter and the BMS (battery management system). Default setting "PLY" is Pylon protocol, including RS485 and Can.	
38	Bms alarm enable	Bms alarm diable(default) 38 bAd	Bms alarm enable 38 bAE
39	Discharge cut off Soc	6%(default) 39 6	When Lithium battery is selected in Program 5, end of discharge Soc should be setted. Setting range is 1%-99%, and should not more than charge stop Soc.
40	Charge stop Soc	97%(default) 40 97	When Lithium battery is selected in Program 5, full charge Soc should be setted. Setting range is 30%-100%, and should not less than end of discharge Soc.
41	Restart Soc	Disable (default) 41 20	When Lithium battery is selected in Program 5, inverter will shut down when battery fully discharged, and inverter will recovery output until battery Soc is above the restart Soc if only PV source recovery. And if Utility is available, inverter will output immediately. Setting range is from 10%-99%, not less than the end of discharge Soc, and not more than the charge stop Soc.
42	Grid-parallel operation	42 FGN	42 FGS

5.5 Display Setting

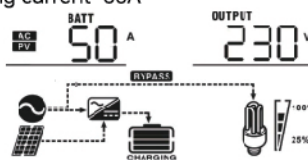
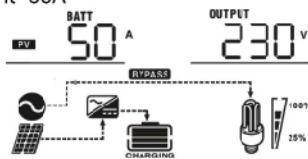
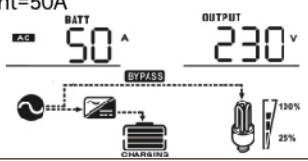
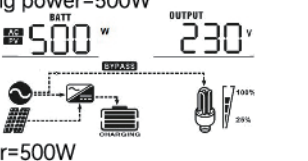

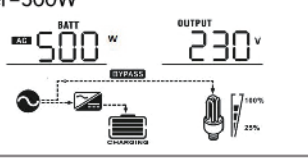
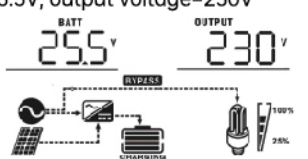
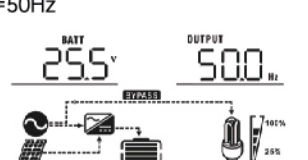

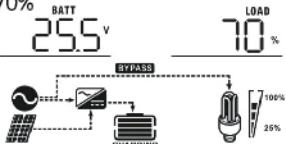
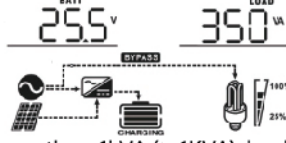
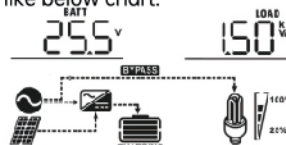
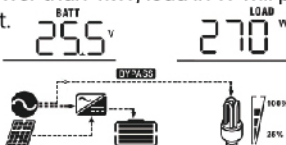
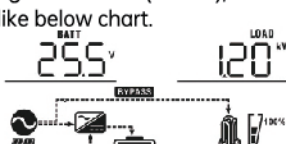
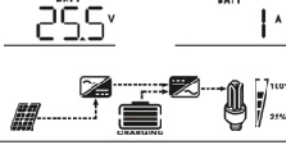

The LCD display information will be switched in turns by pressing "UP" or "DOWN" key. The selectable information is switched as below order: input voltage, input frequency, PV voltage, charging current, charging power, battery voltage, output voltage, output frequency, load percentage, load in Watt, load in VA, load in Watt, DC discharging current, main CPU Version.

Selectable information	LCD display
Input voltage/Output voltage (Default Display Screen)	Input Voltage=230V, output voltage=230V
Input frequency	Input frequency=50Hz
PV voltage	PV voltage=260V
PV current	PV current = 2.5A
PV power	PV power = 500W

<p>Charging current</p>	<p>AC and PV charging current=50A</p>  <p>PV charging current=50A</p>  <p>AC charging current=50A</p> 
<p>Charging power</p>	<p>AC and PV charging power=500W</p>  <p>PV charging power=500W</p>  <p>AC charging power=500W</p> 
<p>Battery voltage and output voltage</p>	<p>Battery voltage=25.5V, output voltage=230V</p> 
<p>Output frequency</p>	<p>Output frequency=50Hz</p> 

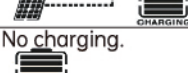



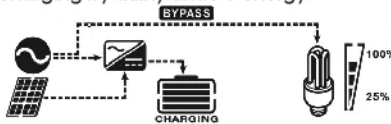
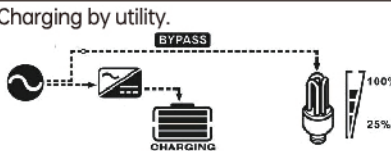
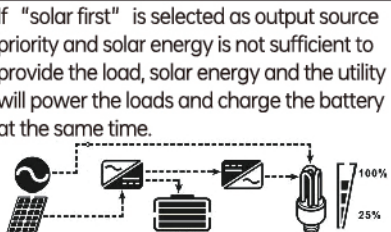

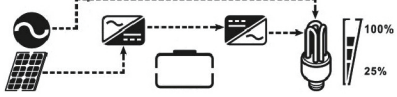
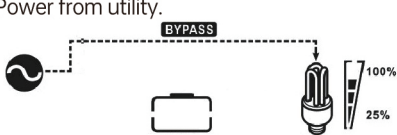
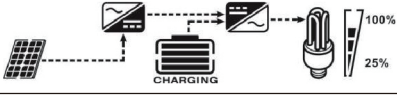
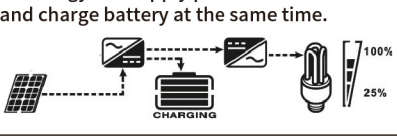
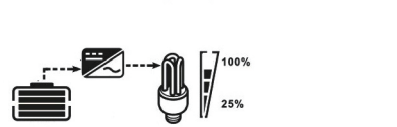
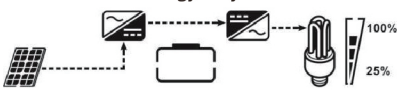

<p>Load percentage</p>	<p>Load percent=70%</p> <p>BATT 25.5 v LOAD 70 %</p> 
<p>Load in VA</p>	<p>When connected load is lower than 1kVA, load in VA will present xxxVA like below chart.</p> <p>BATT 25.5 v LOAD 350 VA</p>  <p>When load is larger than 1kVA ($\geq 1\text{KVA}$), load in VA will present x.xxkVA like below chart.</p> <p>BATT 25.5 v LOAD 150 kVA</p> 
<p>Load in Watt</p>	<p>When load is lower than 1kW, load in W will present xxxW like below chart.</p> <p>BATT 25.5 v LOAD 270 W</p>  <p>When load is larger than 1kW ($\geq 1\text{KW}$), load in W will present x.xkW like below chart.</p> <p>BATT 25.5 v LOAD 1.20 kW</p> 
<p>Battery voltage/DC discharging current</p>	<p>Battery voltage=25.5V, discharging current=1A</p> <p>BATT 25.5 v BATT 1 A</p> 
<p>Lithium battery Soc</p>	<p>Battery voltage is 53.0v, battery soc is 56%</p> <p>BATT 53.0 v M BATT 56 %</p> 
<p>Main CPU version checking</p>	<p>Main CPU version 00014.04</p> <p>01 14 04</p> 

5.6 Operating Mode Description

Operation mode	Description	LCD display
<p>Standby mode</p> <p>Note:</p> <p>*Standby mode: The inverter is not turned on yet but at this time, the inverter can charge battery without AC output.</p>	<p>No output is supplied by the unit but it still can charge batteries.</p>	<p>Charging by utility and PV energy.</p>  <p>Charging by utility.</p>  <p>Charging by PV energy.</p>  <p>No charging.</p> 
<p>Fault mode</p> <p>Note:</p> <p>*Fault mode: Errors are caused by inside circuit error or external reasons such as over temperature, output short circuited and so on.</p>	<p>PV energy and utility can charge batteries.</p>	<p>Charging by utility and PV energy.</p>  <p>Charging by utility.</p>  <p>Charging by PV energy.</p>  <p>No charging.</p> 
<p>Line Mode</p>	<p>The unit will provide output power from the mains. It will also charge the battery in line mode.</p>	<p>Charging by utility and PV energy.</p>  <p>Charging by utility.</p>  <p>If "solar first" is selected as output source priority and solar energy is not sufficient to provide the load, solar energy and the utility will power the loads and charge the battery at the same time.</p> 

Line Mode	The unit will provide output power from the mains. It will also charge the battery in line mode.	<p>If "solar first" is selected as output source priority and battery is not connected, solar energy and the utility will power the loads.</p>  <p>Power from utility.</p> 
Battery Mode	The unit will provide output power from battery and PV power.	<p>Power from battery and PV energy.</p>  <p>PV energy will supply power to the loads and charge battery at the same time.</p>  <p>Power from battery only.</p> 
Battery Mode	The unit will provide output power from battery and PV power.	<p>Power from PV energy only.</p> 

5.7 Fault Reference Code

Fault Code	Fault Event	Icon on
01	Fan is locked when inverter is off.	
02	Over temperature or NTC is not connected well.	
03	Battery voltage is too high	
04	Battery voltage is too low	
05	Output short circuit or over temperature is detected by internal converter components.	
06	Output voltage is too high.	
07	Overload time out	
08	Bus voltage is too high	

09	Bus soft start failed	
51	Over current or surge	
52	Bus voltage is too low	
53	Inverter soft start fails	
55	Over DC voltage in AC output	
57	Current sensor fails	
58	Output voltage is too low	
59	PV voltage is over limitation	
71	Firmware version inconsistent	
72	Current sharing fault	
73	Output voltage different	
80	CAN fault	
81	Host lost	
82	Synchronization lost	
83	Battery voltage detected different	
84	AC input voltage and frequency detected different	
86	AC output mode setting different	

5.8 Warning Indicator

Warning Code	Warning Event	Audible Alarm	Icon flashing
01	Fan is locked when inverter is on.	Beeps three times every second	
02	Over temperature	None	
03	Battery is over-charged	Beeps once every second	
04	Low battery	Beeps once every second	
07	Overload	Beeps once every 0.5 second	
10	Output power derating	Beeps twice every 3 seconds	
13	Bms alarm or comm lost	Beeps twice every seconds	
15	PV energy is low.	Beeps twice every 3 seconds	
16	High AC input (>280VAC) during BUS soft start	None	
	Battery equalization	None	
	Battery is not connected	None	

6. Clearance and maintenance for anti-dust kit

6.1 Overview

Every inverter is already installed with anti-dusk kit in factory. Inverter will automatically detect this kit and activate internal thermal sensor to adjust internal temperature. This kit also keeps dusk from your inverter and increases product reliability in harsh environment.

6.2 Clearance and Maintenance

Step 1: Please loosen the screw in counterclockwise direction on the top of the inverter.

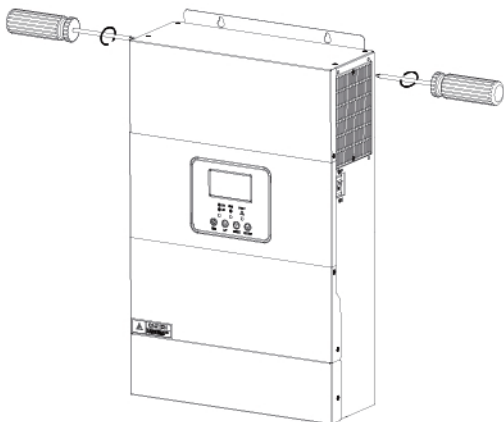

Step 2: Then, dustproof case can be removed and take out air filter foam as shown in below chart.

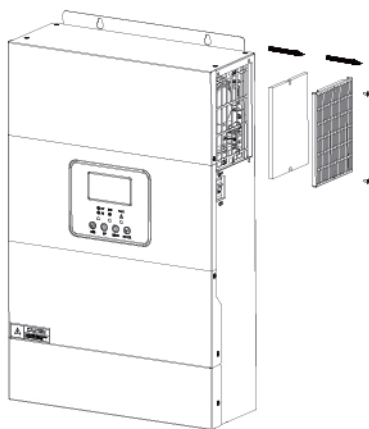

Step 3: Clean air filter foam and dustproof case. After clearance, re-assemble the dust-kit back to the inverter.

NOTICE: The anti-dust kit should be cleaned from dust every one month.

7. Battery Equalization Description

Equalization function is added into charge controller.

It reverses the buildup of negative chemical effects like stratification, a condition where acid concentration is greater at the bottom of the battery than at the top. Equalization also helps to remove sulfate crystals that might have built up on the plates. If left unchecked, this condition, called sulfation, will reduce the overall capacity of the battery. Therefore, it's recommended to equalize battery periodically.

7.1 How to Apply Equalization Function

You must enable battery equalization function in monitoring LCD setting program 30 first.

Then, you may apply this function in device by either one of following methods:

1. Setting equalization interval in program 35.
2. Active equalization immediately in program 36.

7.2 When to Equalize

In float stage, when the setting equalization interval (battery equalization cycle) is arrived, or equalization is active immediately, the controller will start to enter Equalize stage.

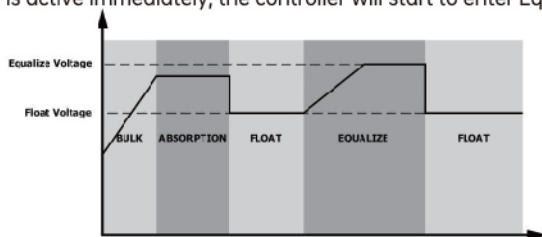

7.3 Equalize charging time and timeout

In Equalize stage, the controller will supply power to charge battery as much as possible until battery voltage raises to battery equalization voltage.

Then, constant-voltage regulation is applied to maintain battery voltage at the battery equalization voltage. The battery will remain in the Equalize stage until set battery equalized time is over.

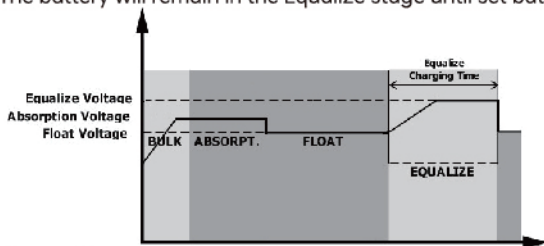

However, in Equalize stage, when battery equalized time is expired and battery voltage doesn't rise to battery equalization voltage point, the charge controller will extend the battery equalized time until battery voltage achieves battery equalization voltage. If battery voltage is still lower than battery equalization voltage when battery equalized timeout setting is over, the charge controller will stop equalization and return to float stage.

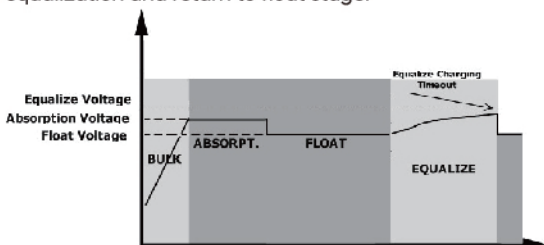

8. Setting for lithium battery

8.1 Lithium Battery Connection

If choosing lithium battery for the inverter, you are allowed to use the lithium battery only which we have configured. There're two connectors on the lithium battery, RJ45 port of BMS and power cable.

Please follow below steps to implement lithium battery connection:

- 1). Assemble battery terminal based on recommended battery cable and terminal size (same as Lead acid, see section Lead-acid Battery connection for details).
- 2). Connect the end of RJ45 port of battery to BMS(RS485) communication port of inverter.

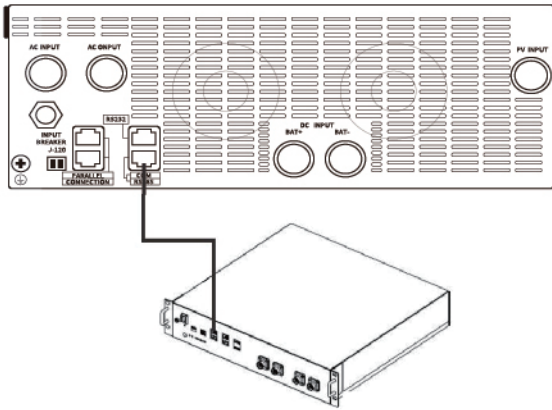

- If choosing lithium battery, make sure to connect the BMS communication cable between the battery and the inverter. This communication cable delivers information and signal between lithium battery and the inverter. This information is listed below:
Re-configure charging voltage, charging current and battery discharge cut-off voltage according to the lithium battery parameters.
- Have the inverter start or stop charging according to the status of lithium battery.

8.2 Battery communication cable port definition

Connect the end of RS485 of battery to RS485 communication port of inverter

Make sure the lithium battery port connects to the inverter is Pin to Pin, the communication cable is inside of package and the inverter port pin assignment shown as below:

Pin number	Port function
PIN1、PIN8	RS485-B
PIN2、PIN7	RS485-A
PIN3	GND
PIN4	CAN-H
PIN5	CAN-L
PIN6	GND

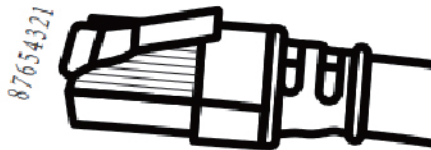

8.3 LCD setting

After connecting, you need to finish and confirm some settings as follow:

Program	Description	Selectable option	
05	Battery type	05 <u>AGn</u>	AGM (default)
		05 <u>FLd</u>	Flooded
		05 <u>LIb</u>	Lithium battery
		05 <u>USE</u>	User-Defined
37	Comm protocol	37 <u>PLY</u>	《CAN-Bus-protocol-PYLON-low-voltage-V2.0.6_220510》、《PYLON low voltage Protocol RS485》
		37 <u>FlE</u>	Support Ritar 485 protocol V1.7
		37 <u>Jdb</u>	Support Jabaida 485 general protocol V4
39	Discharge cut off Soc	39 <u>6</u>	Default 6%,Setting range is 1%-99%,and should not more than charge stop Soc.
40	Charge stop Soc	40 <u>97</u>	Default 97%,Setting range is 30%-100%, and should not less than charge stop Soc.
41	Restart Soc	41 <u>20</u>	Default 20%,Setting range is from 10%-99%, not less than the end of discharge Soc, and not more than the charge stop Soc.

8.4 LCD Display

If communication between the inverter and battery is successful, the Li icon will always light, or flash if communication unsuccessful:

Item	Description	LCD display
1	Communication successful icon	
2	Lithium battery Soc	

9. Specifications

9.1 Table 1 Line Mode Specifications

INVERTER MODEL	3.5KVA	5.5KVA
Rated Output Power	3.5KVA/3.5KW	5.5KVA/5.5KW
Input Voltage Waveform	Sinusoidal (utility or generator)	
Nominal Input Voltage	230Vac	
Low Loss Voltage	170Vac±7V (UPS); 90Vac±7V (Appliances)	
Low Loss Return Voltage	180Vac±7V (UPS); 100Vac±7V (Appliances)	
High Loss Voltage	280Vac±7V	
High Loss Return Voltage	270Vac±7V	
Max AC Input Voltage	300Vac	
Nominal Input Frequency	50Hz / 60Hz (Auto detection)	
Low Loss Frequency	40±1Hz	
Low Loss Return Frequency	42±1Hz	
High Loss Frequency	65±1Hz	
High Loss Return Frequency	63±1Hz	
Output Short Circuit Protection	Line mode: Circuit Breaker Battery mode: Electronic Circuits	
Efficiency (Line Mode)	>95% (Rated R load, battery full charged)	
Transfer Time	10ms typical (UPS); 20ms typical (Appliances)	
<p>Output power derating:</p> <p>When AC input voltage drops to 95V or 170V depending on models, the output power will be derated</p>	<p>The graph illustrates the output power derating characteristics. The vertical axis represents Output Power, and the horizontal axis represents Input Voltage. Key points on the graph include: <ul style="list-style-type: none"> At 90V input voltage, the output power is limited to 50% of the rated power. Between 90V and 170V, the output power increases linearly from 50% to the full rated power. From 170V to 280V, the output power remains constant at the rated power level. </p>	

9.2 Table 2 Inverter Mode Specifications

INVERTER MODEL	3.5KVA	5.5KVA
Rated Output Power	3.5KVA/3.5KW	5.5KVA/5.5KW
Output Voltage Waveform	Pure Sine Wave	
Output Voltage Regulation	230Vac±5%	
Output Frequency	50Hz or 60Hz	
Peak Efficiency	>93.5%	
Overload Protection	5s@ ≥ 140% load; 10s@100%~140% load	
Surge Capacity	2* rated power for 5 seconds	
Nominal DC Input Voltage	24.0Vdc	48.0Vdc
Cold Start Voltage	23.0Vdc	46.0Vdc
Low DC Warning Voltage		
@ load < 20%	22.0Vdc	44.0Vdc
@ 20% ≤ load < 50%	21.4Vdc	42.8Vdc
@ load ≥ 50%	20.2Vdc	40.4Vdc
Low DC Warning Return Voltage		
@ load < 20%	23.0Vdc	46.0Vdc
@ 20% ≤ load < 50%	22.4Vdc	44.8Vdc
@ load ≥ 50%	21.2Vdc	42.4 Vdc
Low DC Cut-off Voltage		
@ load < 20%	21.0Vdc	42.0Vdc
@ 20% ≤ load < 50%	20.4Vdc	40.8Vdc
@ load ≥ 50%	19.2Vdc	38.4Vdc

9.3 Table 3 Charge Mode Specifications

INVERTER MODEL		3.5KVA	5.5KVA
Max Charging Current (PV+AC)		100Amp (@VI/P=230Vac)	
AC Charging Current (Max)		60Amp (@VI/P=230Vac)	
Bulk Charging Voltage	Flooded Battery	29.2 Vdc	58.4Vdc
	AGM / Gel Battery	28.2Vdc	56.4Vdc
Floating Charging Voltage		27.0Vdc	54.0Vdc
Overcharge Protection		33.0Vdc	63.0Vdc
Charging Algorithm		3-Step	
Charging Curve			
Solar Input			
INVERTER MODEL		3.5KVA	5.5KVA
Max. PV Array Power		5000W	6000W
Nominal PV Voltage		240Vdc	
Start-up Voltage		160Vdc +/- 10Vdc	
PV Array MPPT Voltage Range		120~450Vdc	
Max. PV Array Open Circuit Voltage		500Vdc	
Max. Input Current		15	18
Max Charging Current (AC charger plus solar charger)		100Amp	

9.4 Table 4 General Specifications

INVERTER MODEL	3.5KVA	5.5KVA
Safety Certification	CE	
Operating Temperature Range	-10°C to 55°C	
Storage temperature	-15°C~ 60°C	
Humidity	5% to 95% Relative Humidity (Non-condensing)	
Dimension(D*W*H), mm	448x295x105(122)	
Net Weight, kg	8.2(8.5)	9.9(10.2)

10. TROUBLE SHOOTING

Problem	LCD/LED/Buzzer	Explanation / Possible cause	What to do
Unit shuts down automatically during startup process.	LCD/LEDs and buzzer will be active for 3 seconds and then complete off.	The battery voltage is too low	1.Re-charge battery. 2.Replace battery.
No resafter power on.	No indication.	1.The battery voltage is far too low. 2.Battery polarity is connected reversed.	1.Check if batteries and the wiring are connected well. 2.Re-charge battery. 3.Replace battery.
Mains exist but the unit works in battery mode.	Input voltage is displayed as 0 on the LCD and green LED is flashing.	Input protector is tripped	Check if AC breaker is tripped and AC wiring is connected well.
	Green LED is flashing.	Insufficient quality of AC power (Shore or Generator)	1.Check if AC wires are too thin and/or too long. 2.Check if generator (if applied) is working well or if input voltage range setting is correct. (UPS Appliance)
	Green LED is flashing.	Set "Solar First" as the priority of output source.	Change output source priority to Utility first.
When the unit is turned on,internal relay is switched on and off repeatedly.	LCD display and LED sare flashing	Battery is disconnected.	Check if battery wires are connected well.
Buzzer beeps continuously and red LED is on.	Fault code 07	Overload error. The inverter is overload 110% and time is up.	Reduce the connected load by switching off some equipment.
	Fault code 05	Output short circuited.	Check if wiring is connected well and remove abnormal load.
	Fault code 02	Internal temperature of inverter component is over 100°C.	Check whether the air flow of the unit is blocked or whether the ambient temperature is too high.
	Fault code 03	The battery voltage is too high.	Check if spec and quantity of batteries are meet requirements.
	Fault code 01	Fan fault	Check whether the fan is lock, or replace the fan.
	Fault code 06/58	Output abnormal (Inverter voltage below than 190Vac or is higher than 260Vac)	Reduce the connected load.
	Fault code 08	Bus voltage is too high	Restart the device, if the fault repeat frequently, please contact after service.
	Fault code 09/53/57	Internal components failed.	Please contact after service or return to repair center.
	Fault code 51	Over current or surge.	Restart the devise, if fault repeat frequently, please contact the after service.
	Fault code 52	Bus voltage is too low.	
Fault code 55	Inverter voltage Dc component is over		
Fault code 80	communication abnormal	Please check the connection of parallel comm cable, and then restart the device, if the fault happens again, please contact after service.	

11. Parallel Installation Guide

11.1 Instruction

This inverter can be used in parallel with two different operation modes.

1.Parallel operation in single phase with up to 6 units. The supported maximum output power is 33KVA/33KW

2.Maximum 6 units work together to support three-phase equipment. 5 units support one phase maximum. The supported maximum output power is 33KVA/33KW and one phase can be up to 27.5KVA/27.5KW

NOTE: If this unit is bundled with share current cable and parallel cable, this inverter is default supported parallel operation.

11.2 Package Contents

In parallel kit, you will find the following items in the package:



Parallel communication cable

11.3 Mounting the Unit

When installing multiple units, please follow below chart.

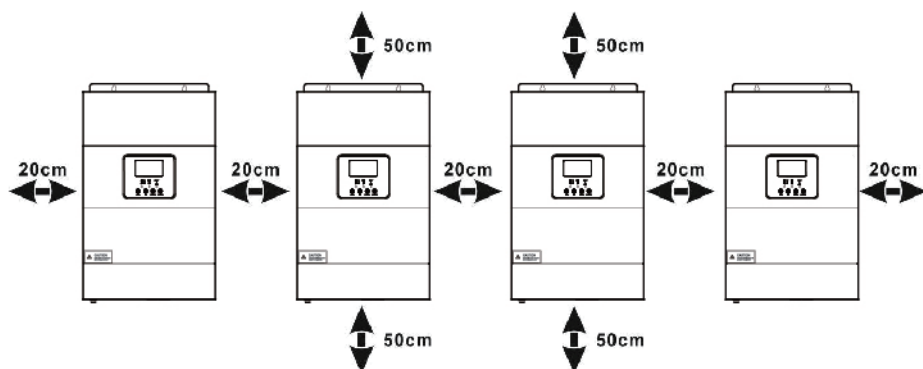

NOTE: For proper air circulation to dissipate heat, allow a clearance of approx. 20 cm to the side and approx. 50 cm above and below the unit. Be sure to install each unit in the same level.

11.4 Wiring Connection

NOTICE: It's requested to connect to battery for parallel operation.
The cable size of each inverter is shown as below:
Recommended battery cable and terminal size for each inverter:

Model	Wire Size	Cable mm ²	Dimensions		Torque value
			L1 (mm)	L2 (mm)	
5.5KVA	2AWG	38	3	18	2~ 3 Nm

Stripping Length:

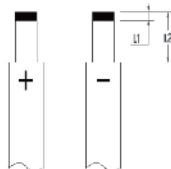

WARNING: Be sure the length of all battery cables is the same. Otherwise, there will be voltage difference between inverter and battery to cause parallel inverters not working. Parallel connection must be connected with the battery.

Recommended AC input and output cable size for each inverter:

Model	AWG no.	Torque
5.5KVA	8 AWG	1.4~1.6Nm

You need to connect the cables of each inverter together. Take the battery cables for example: You need to use a connector or bus-bar as a joint to connect the battery cables together, and then connect to the battery terminal. The cable size used from joint to battery should be X times cable size in the tables above. "X" indicates the number of inverters connected in parallel. Regarding AC input and output, please also follow the same principle.

CAUTION!! Please install the breaker at the battery and AC input side. This will ensure the inverter can be securely disconnected during maintenance and fully protected from over current of battery or AC input. The recommended mounted location of the breakers is shown in the figures in Point 5.

Recommended breaker specification of battery for each inverter:

Model	1 unit*
5.5KVA	100A/60VDC

*If you want to use only one breaker at the battery side for the whole system, the rating of the breaker should be X times current of 1 unit. "X" indicates the number of inverters connected in parallel. Recommended breaker specification of AC input with single phase:

Model	2 units	3 units	4 units	5 units	6 units
5.5KVA	100A	150A	200A	250A	300A

Note1: Also, you can use 40A breaker (50A for 5.5KVA) for only 1 unit, and each inverter has a breaker at its AC input.

Recommended battery capacity

Inverter parallel numbers	2	3	4	5	6
Battery Capacity	400AH	600AH	800AH	1000AH	1200AH



WARNING! Be sure that all inverters will share the same battery bank. Otherwise, the inverters will transfer to fault mode.

Communicating with battery BMS in parallel system

- 1) Only support common battery installation
- 2) Use RJ45 cable to connect any one of inverters (no need to connect to a specific inverter) and Lithium battery.

12. Parallel Operation in Single phase

12.1 Two inverters in parallel:

Power Connection

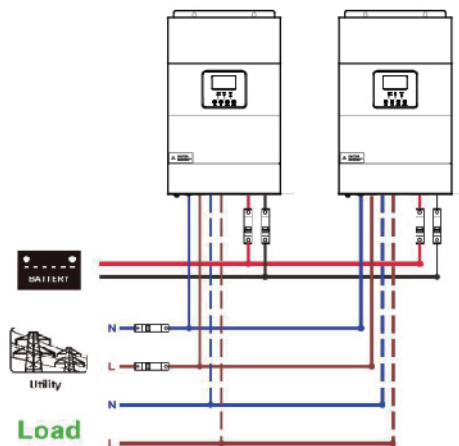

Communication Connection

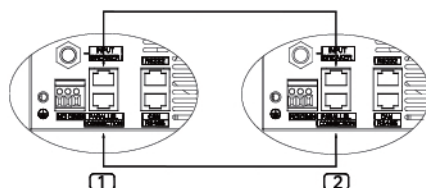

Three inverters in parallel:

Power Connection

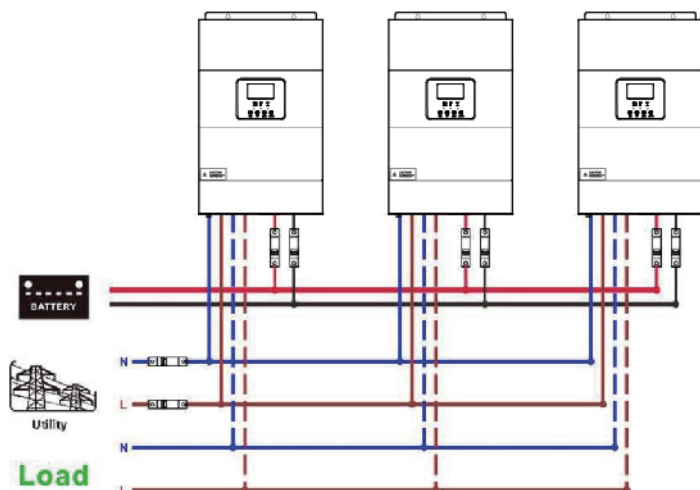

Communication Connection

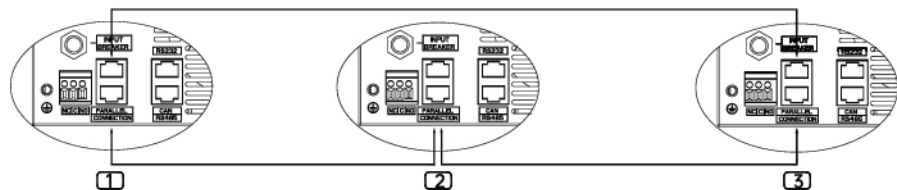

Four inverters in parallel:

Power Connection

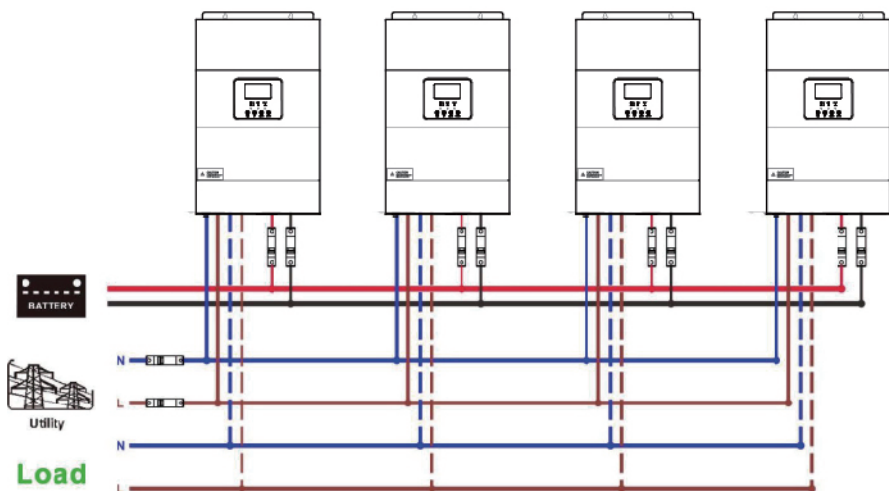

Communication Connection

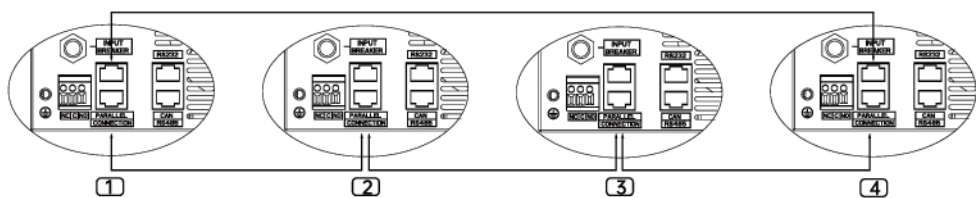

Five inverters in parallel:

Power Connection

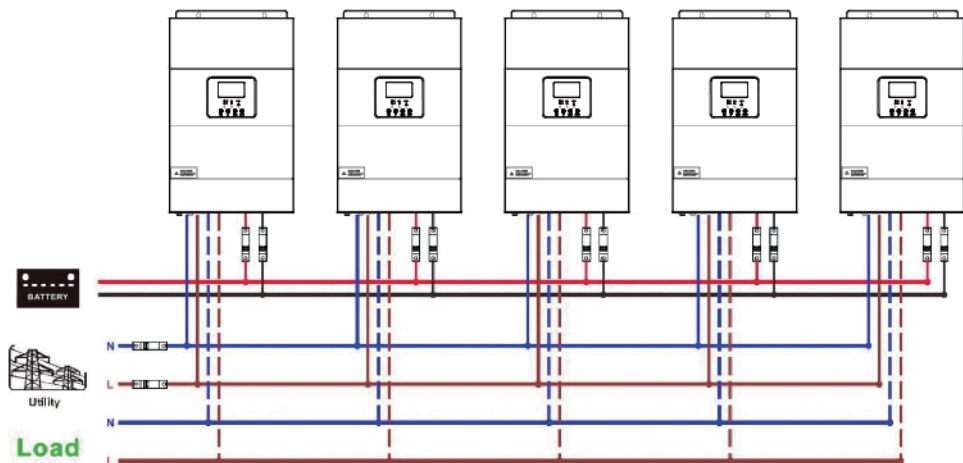

Communication Connection

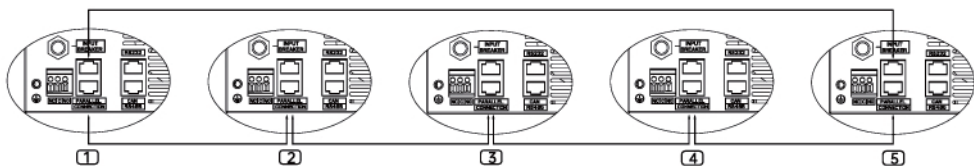

Six inverters in parallel:

Power Connection

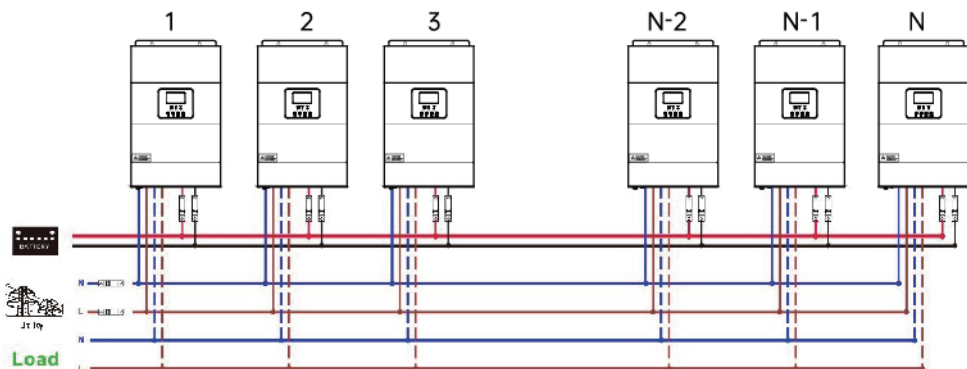

Communication Connection

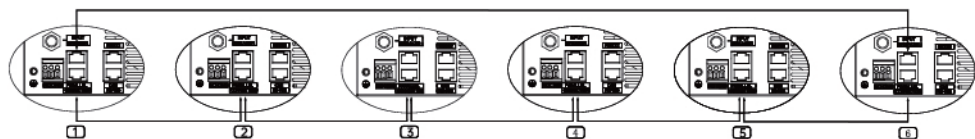

Note: $N_{max}=6$ units.

Parallel Operation in three phase

6.1 Matters Needing Attention In Three-phase Parallel Operation:

1. Parallel operation in Three phase with up to 6 units.
2. **WARNING:** It's required to connect battery for parallel operation, it is forbidden to use parallel without batteries
3. **WARNING:** It is forbidden for inverter to share the same solar panel group.
4. **WARNING:** Make sure all cables are of the same length, Otherwise, there will be voltage difference between inverter and battery to cause parallel inverters not working.
5. Set the parameters of each inverter independently (working mode, three- phase parallel function and set A/B/C phase sequence).

WARNING: When working in parallel, the working mode of each inverter must be the same, including working mode, output frequency.

6. After setting the parameters, turn on each inverter in turn.
7. **WARNING:** When running in parallel, all inverters must share the battery pack.
8. **WARNING:** Do not connect the current sharing cable between the inverters which are in different phase. Otherwise, it may damage inverters.

12.2 Three-phase Parallel Operation Cable Connection

1. One inverters in each phase:

Power Connection:

NOTE: The following picture is only a schematic diagram of the equipment .Maybe there exist some differences due to structural upgrade.

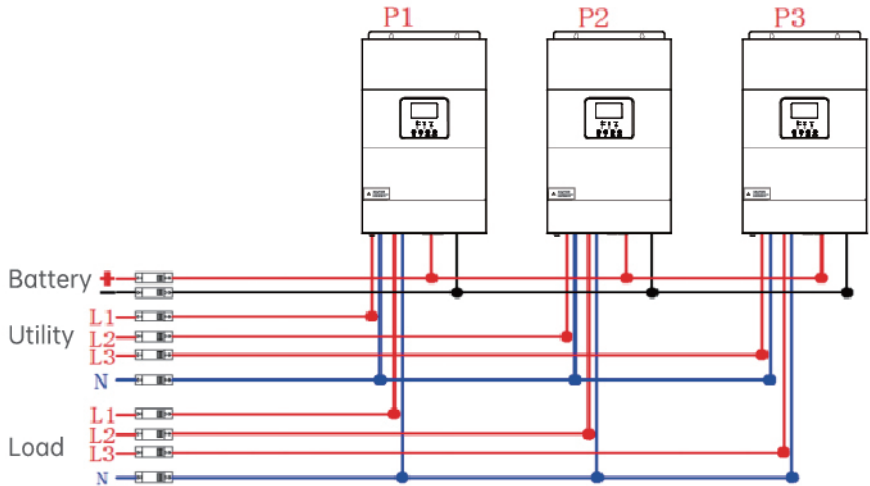

NOTE:P1: A-phase, P2: B-phase, P3: C-phase

Communication Connection

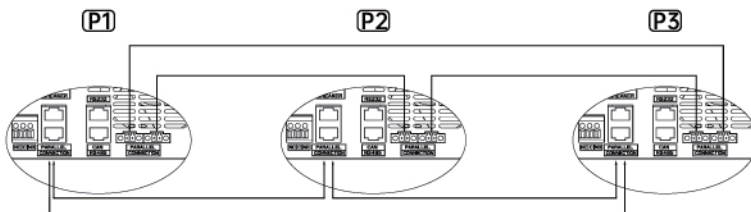

2. Two inverters in each phase:

Power Connection:

NOTE: The following picture is only a schematic diagram of the equipment .Maybe there exist some differences due to structural upgrade.

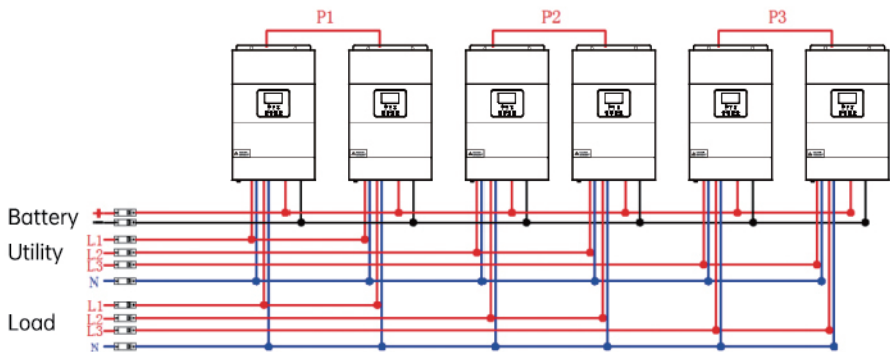

NOTE:P1: A-phase, P2: B-phase, P3: C-phase

Communication Connection

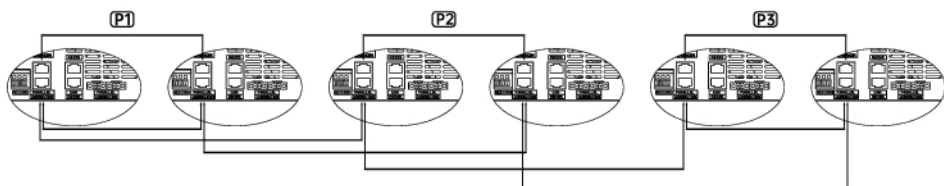

3. Four inverters in one phase and one inverter for the other two phases:

Power Connection:

NOTE: The following picture is only a schematic diagram of the equipment .Maybe there exist some differences due to structural upgrade.

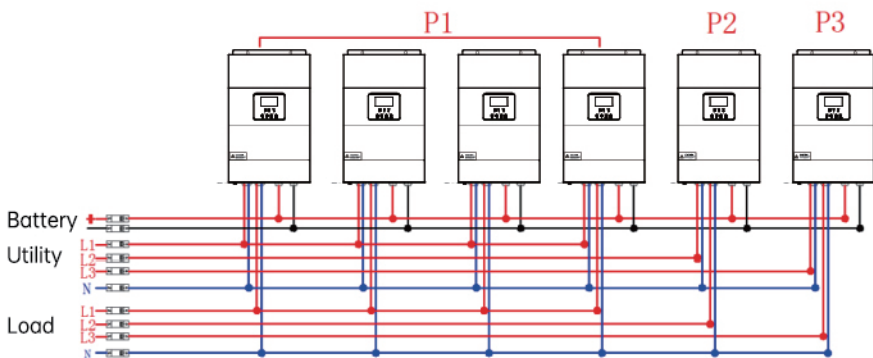

NOTE:P1: A-phase, P2: B-phase, P3: C-phase

Communication Connection

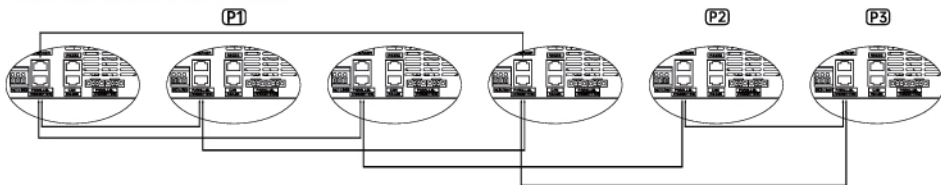

4. Three inverters in one phase, two inverters in second phase and one inverter for the third phase:

Power Connection:

NOTE: The following picture is only a schematic diagram of the equipment .Maybe there exist some differences due to structural upgrade.

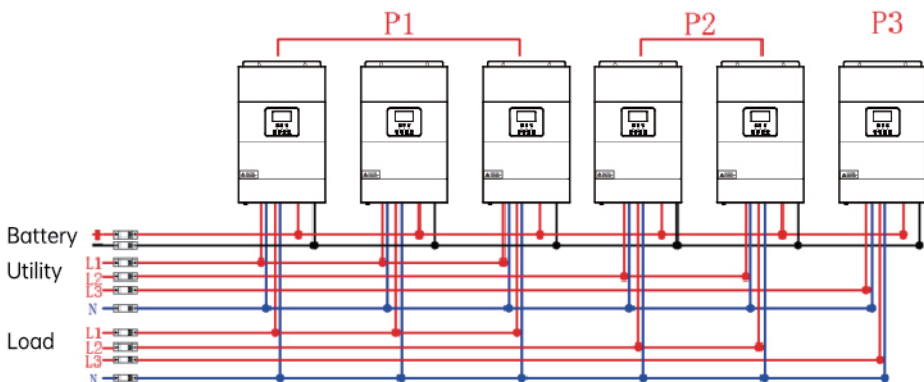

NOTE:P1: A-phase, P2: B-phase, P3: C-phase

Communication Connection

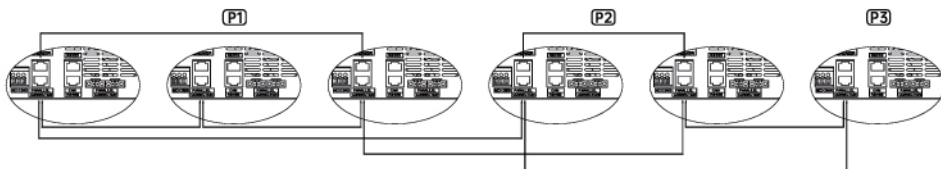

12.3 PV Connection

Please refer to user manual of single unit for PV Connection.

CAUTION: Each inverter should connect to PV modules separately.

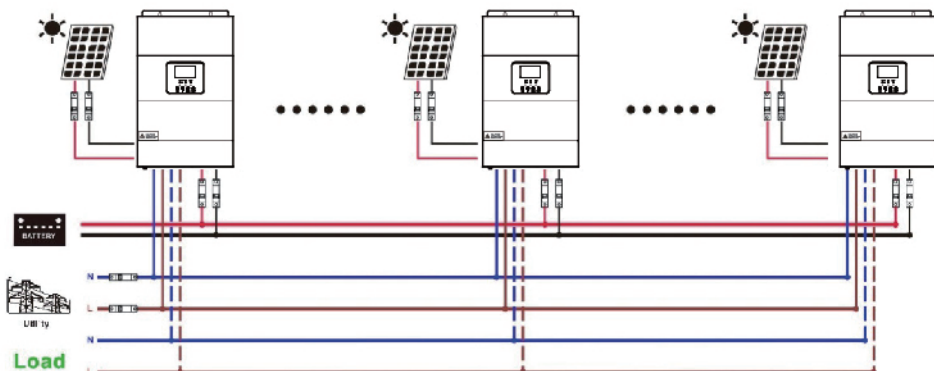

13. Technical Parameters

SC HF 3500-24

SC HF 5500-48

Model	SC HF 3500-24	SC HF 5500-48
Rated Power	3500VA/3500W	5500VA/5500W
INPUT(AC)		
Voltage	230V AC	
Optional Voltage Range	170-280V AC(For Personal Computers);90-280V AC(For Home Appliances)	
Frequency Range	50Hz/60Hz(Auto Sensing)	
OUTPUT(AC)		
AC stabilized voltage	230V AC±5%	
Surge Power	7000VA	11000VA
Peak efficiency	93.5%	
Switching time	10ms(ForPersonal Computers);20ms(For Home Appliances)	
Wave form	Pure Sine Wave	
BATTERY		
Battery type	Lead acid + Lithium battery	
Battery voltage range	21-30V	42-60V
Charging curve	Three-Stage	
Lithium battery charging strategy	Adaptive to lithium battery	
Solar Charge & AC Charge		
Maximum photovoltaic power	3500W	5500W
Maximum PV open circuit voltage	500V DC	
MPPT Range & Working Voltage	120~450V DC	
Maximum Solar Charging Current	100A	
Maximum AC charging current	60A	
Solar Charger Type	MPPT	
General DaTa		
Product size(mm)	302*490*110	
Package size(mm)	346*536*178	
Net Weight(kgs)	8.44	9.7
Communication Interface	RS232/RS485CAN /Drycontact	
Relative Humidity	5% to 95%	
Operating Temperature	-10°C to 50°C	
Storage Temperature	-15°C to 60°C	

Note:Product specifications are subject to change without further notice.

13. Technical Parameters

SC HF 3500-24

SC HF 5500-48

Model	SC HF 3500-24	SC HF 5500-48
Rated Power	3500VA/3500W	5500VA/5500W
INPUT(AC)		
Voltage	230V AC	
Optional Voltage Range	170-280V AC(For Personal Computers);90-280V AC(For Home Appliances)	
Frequency Range	50Hz/60Hz(Auto Sensing)	
OUTPUT(AC)		
AC stabilized voltage	230V AC±5%	
Surge Power	7000VA	11000VA
Peak efficiency	93.5%	
Switching time	10ms(ForPersonal Computers);20ms(For Home Appliances)	
Wave form	Pure Sine Wave	
BATTERY		
Battery type	Lead acid + Lithium battery	
Battery voltage range	21-30V	42-60V
Charging curve	Three-Stage	
Lithium battery charging strategy	Adaptive to lithium battery	
Solar Charge & AC Charge		
Maximum photovoltaic power	3500W	5500W
Maximum PV open circuit voltage	500V DC	
MPPT Range & Working Voltage	120~450V DC	
Maximum Solar Charging Current	100A	
Maximum AC charging current	60A	
Solar Charger Type	MPPT	
General DaTa		
Product size(mm)	302*490*110	
Package size(mm)	346*536*178	
Net Weight(kgs)	8.44	9.7
Communication Interface	RS232/RS485CAN /Drycontact	
Relative Humidity	5% to 95%	
Operating Temperature	-10°C to 50°C	
Storage Temperature	-15°C to 60°C	

Note:Product specifications are subject to change without further notice.

