

MU30H Series

30W, Wide 4:1 Input Range, 1.5KV Isolation, DIP2"x1" Package DC/DC Converters

Features

- ▶ Rated power: 30W Max
- ▶ Input voltage range 4:1
- ▶ Regulated output with 10% trimming range
- ▶ High efficiency up to 90%
- ▶ Isolation voltage 1.5KVDC
- ▶ Remote On/Off control
- ▶ Operating temperature range: -40 ~ +80°C ambient
- ▶ RoHS compliant
- ▶ Standard 2"x1" package
- ▶ Six-sided metal shielding package
- ▶ Under voltage, over voltage, over current, and short circuit protection
- ▶ Designed to meet UL/EN/IEC 62368-1
- ▶ 3 year warranty



Overview

The MU30H series are 1.5KV isolated 30Watt DC/DC converters with standard DIP2"x1" footprint. Designed with high efficiency, they operate in a wide temperature range from -40°C to +80°C. Other features include wide 4:1 input voltage range, remote on/off control, under voltage, over voltage, over current, and short circuit protections. These converters are ideally suitable for industrial control system, measurement equipment, telecom, wireless network.

Model Numbers

Model Number	Input Voltage [VDC]			V _{OUT} [VDC]	Output Current [mA]		Efficiency [%] Typ.	Capacitive Load [uF] Max.
	Nom.	Range	*Max.		Max.	Min.		
MU30H-2403	24	9~36	40	3.3	6000	0	85	10000
MU30H-2405	24	9~36	40	5	6000	0	86	10000
MU30H-2409	24	9~36	40	9	3333	0	88	4700
MU30H-2412	24	9~36	40	12	2500	0	90	2400
MU30H-2415	24	9~36	40	15	2000	0	90	1680
MU30H-2424	24	9~36	40	24	1250	0	90	680
MU30H-2405D	24	9~36	40	±5	±3000	0	86	2000
MU30H-2412D	24	9~36	40	±12	±1250	0	89	1250
MU30H-2415D	24	9~36	40	±15	±1000	0	89	680
MU30H-2424D	24	9~36	40	±24	±625	0	89	470
MU30H-4803	48	18~75	80	3.3	6000	0	86	10000
MU30H-4805	48	18~75	80	5	6000	0	87	10000
MU30H-4812	48	18~75	80	12	2500	0	88	2700
MU30H-4815	48	18~75	80	15	2000	0	89	1680
MU30H-4824	48	18~75	80	24	1250	0	87	680

Model Numbers [continued]

Model Number	Input Voltage [VDC]			V _{OUT} [VDC]	Output Current [mA]		Efficiency [%] Typ.	Capacitive Load [uF] Max.
	Nom.	Range	*Max.		Max.	Min.		
MU30H-4805D	48	18~75	80	±5	±3000	0	86	2000
MU30H-4812D	48	18~75	80	±12	±1250	0	88	1250
MU30H-4815D	48	18~75	80	±15	±1000	0	88	680

* Input voltage exceed the Max. value may cause permanent damage.

* Only typical models are listed. Other models may be available upon request.

Electrical Specifications

Unless otherwise indicated, specifications are measured at T_A=25°C, nominal input voltage, full load after warm up.

Parameters	Conditions	Min.	Typ.	Max.	Unit	Note
Input current Full load, V _{IN, Nom} =24V	V _{OUT} =3.3V V _{OUT} =5V Others	-	970 1454 1388	-	mA	
Input current Full load, V _{IN, Nom} =48V	V _{OUT} =3.3V V _{OUT} =5V Others		474 710 702	-	mA	
Input current No load, V _{IN, Nom} =24V	V _{OUT} =3.3V V _{OUT} =5V Others	-	60 60 6	-	mA	
Input current No load, V _{IN, Nom} =48V	V _{OUT} =3.3V V _{OUT} =5V Others		20 20 5	-	mA	
Reflected ripple current		-	40	-	mA	
Input voltage surge 1 second max	V _{IN, Nom} =24V V _{IN, Nom} =48V	-0.7 -0.7	-	50 100	VDC	
Startup input voltage	V _{IN, Nom} =24V V _{IN, Nom} =48V	-	-	9 18	VDC	
Startup time	Resistive load	-	10	-	mS	
Input under voltage shutdown	V _{IN, Nom} =24V V _{IN, Nom} =48V	5.5 12	6.5 15.5	-	VDC	
Remote On/Off control "Ctrl" pin open or logic high [ON] "Ctrl" pin grounded or logic low [OFF]	Logic high Logic low Ctrl pin current	3.5 0 -	- - 5	12 1.2 8	VDC VDC mA	Positive Logic

Electrical Specifications [continued]

Parameters	Conditions	Min.	Typ.	Max.	Unit	Note
Output voltage accuracy	$I_{OUT}=5\%$ to 100%	-	± 1	± 3	%	
Line regulation Full load, $V_{IN}=V_{IN, Min}$ to $V_{IN, Max}$	Main output	-	± 0.2	± 0.5	%	
	Other output	-	± 0.5	± 1.0	%	
Load regulation $I_{OUT}=5\%$ to 100% of $I_{OUT, rated}$	Main output	-	± 0.5	± 1.0	%	
	Other output	-	± 0.5	± 1.5	%	
Cross regulation $+I_{OUT}=50\%$, $-I_{OUT}=10\%$ to 100%	Dual output models	-	-	± 5	%	
Output ripple and noise 20MHz bandwidth, peak to peak	Single	-	50	100	mVp-p	
	Dual	-	50	150	mVp-p	
Temperature coefficient	Full load	-	-	0.03	%/°C	
Dynamic load response $I_{OUT}=25\% \sim 50\% \sim 75\%$ of $I_{OUT, rated}$	Peak deviation	-	± 5	± 8	% V_{OUT}	
	Recovery time	-	300	500	μS	
Output voltage trim	Trim range	-	-	± 10	% V_{OUT}	
Output over voltage protection		110	-	160	% V_{OUT}	
Output over current protection		110	-	190	% I_{OUT}	
Output short circuit protection		Continuous, automatic recovery				
Input filter		PI filter				
Hot plug		None				

* Operating with less than 5% of rated load will not cause damage to the converters, but the performances data may not fall into the specifications, and stable operating is not assured.

General Specifications

Parameters	Conditions	Min.	Typ.	Max.	Unit	Note
Isolation voltage 1 minute, leakage current 1mA max.	I/P to O/P	1500	-	-	VDC	
Isolation resistance Tested at 500VDC	I/P to O/P	1000	-	-	M ohm	
Isolation capacitance 100KHz, 0.1V	I/P to O/P	-	2000	-	pF	
Switching frequency*	Full load	-	330	-	KHz	PWM mode
Operating temperature	See "Derating Curve"	-40	-	+80	°C	
Storage temperature		-55	-	+125	°C	
Storage humidity	None condensing	5	-	95	%RH	
Pin soldering resistance 1.5mm away from case for 10 sec		-	-	300	°C	
Vibration		IEC/EN61373 - Category 1, Grade B				
Cooling method		Free air convection				
Case material		Aluminum alloy				
MTBF	MIL-HDBK-217F	>1,000,000 Hours, T _A =25°C				
Design based on standards		UL/EN/IEC 62368-1				
Safety certifications		EN/IEC 62368-1				
EMC		CISPR32, EN55032 Class B with external circuit IEC/EN61000-4-2, 3, 4, 5, 6				
Size, and Weight		50.8 x 25.4 x 12 mm, 30g				

* Switching frequency is measured at full load. The converter reduces the switching frequency at low load [less than 50% load] for better efficiency.

MU30H Series

30W, Wide 4:1 Input Range, 1.5KV Isolation, DIP2"X1" Package DC/DC Converters

Characteristic Curves

Derating Curve

Output vs Ambient Temperature

Single output

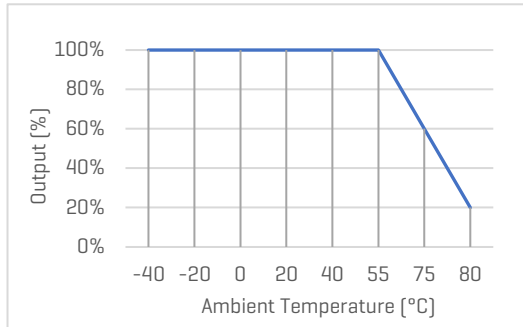

Dual output

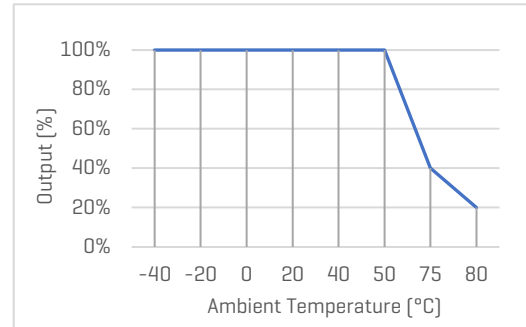

Efficiency Curve

Efficiency vs Input Voltage

MU30H-2405, with full Load

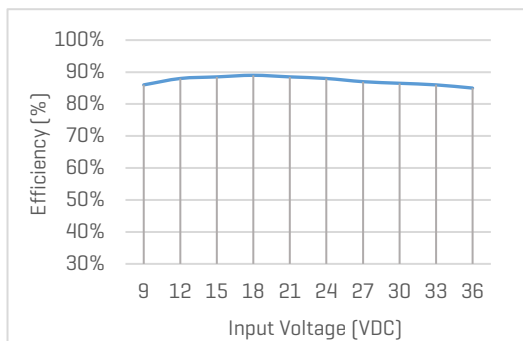

Efficiency vs Load

MU30H-2405, with nominal input voltage

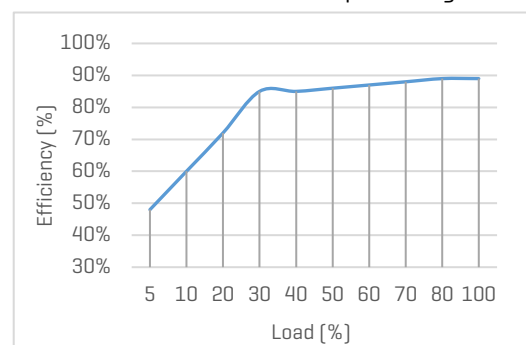

MU30H-4815D, with full Load

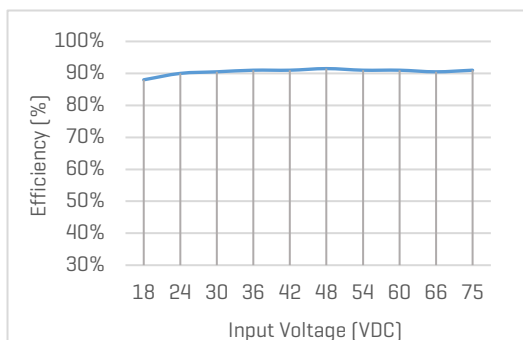

MU30H-4815D, with nominal input voltage

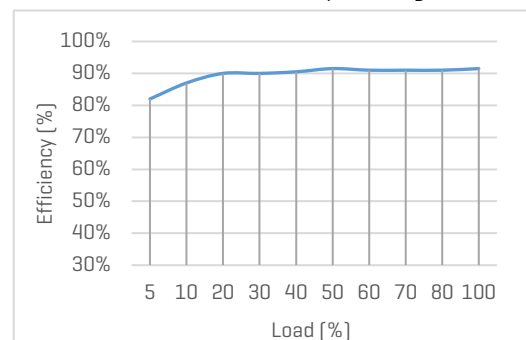

MU30H Series

30W, Wide 4:1 Input Range, 1.5KV Isolation, DIP2"X1" Package DC/DC Converters

Recommended Application Circuit

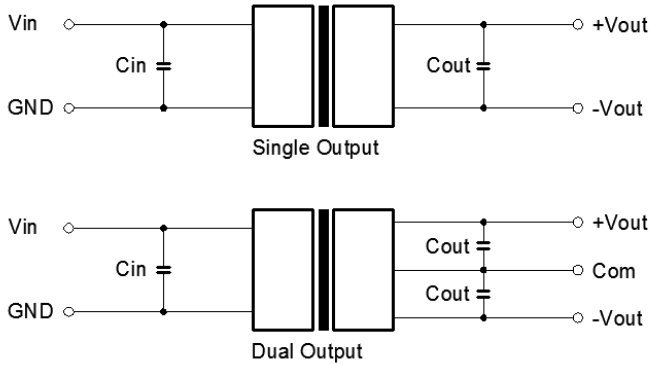

Note

*Typical application circuit is to further lower the input and output ripple. It is not required for general use.
 *Recommended component specifications are typical values. Excessive external capacitive load may cause startup problem.

Figure 1. Typical external circuit

[Table 1] Recommended component spec

Input voltage	24V	48V
C_{IN}	100uF, 50V	100uF, 100V

[Table 2] Recommended component spec

Output voltage	3.3 ... 9V	12 ... 24V	$\pm 5 ... \pm 15V$	$\pm 24V$
C_{OUT}	220uF, 24V	100uF, 50V	220uF, 24V	100uF, 50V

Circuit for EMC Enhancement, single output

*Use this application circuit to meet Class B EMC performance.

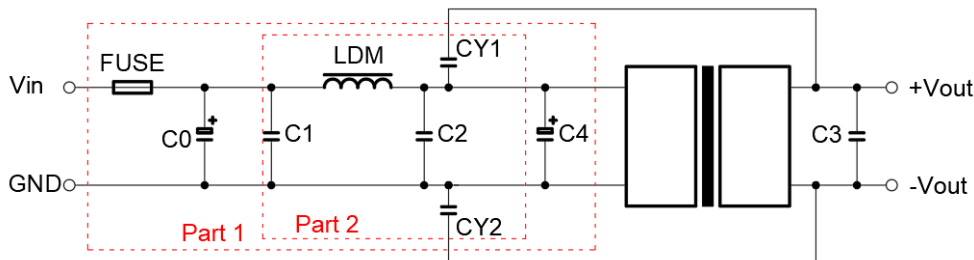

Figure 2. Circuit for EMC enhancement

[Table 3] Recommended component spec

Component	LDM	C0, C4	C1, C2	CY1, CY2
$V_{IN}=24V$	2.2uH, 4A	330uF, 50V	4.7uF, 50V	1nF, 2KV
$V_{IN}=48V$	2.2uH, 2A	330uF, 100V	4.7uF, 100V	1nF, 2KV

* Fuse to be selected according to application needs.

* C3 refer to relative C_{OUT} values in Table 2.

Recommended Application Circuit [continued]

Circuits for Output Trim

* Components within the red block are internal components of the converter.

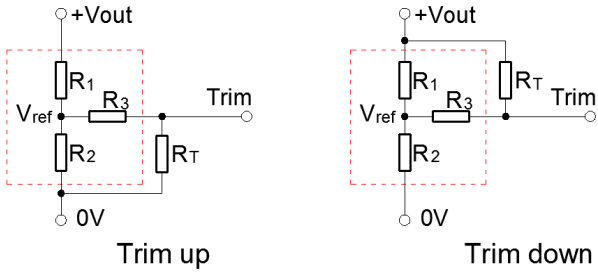

[Table 4] Internal Component Spec

V _{OUT} [V]	R1 [K Ohm]	R2 [K Ohm]	R3 [K Ohm]	V _{ref} [V]
3.3	10	6.064	13.622	1.24
5	2.4	2.344	13.622	2.5
12	8.2	2.153	17.346	2.5
15	12	2.388	21.016	2.5
24	10	1.158	10.714	2.5

* The formulas to calculate the desired resistance of Trim resistor "R_T".

$$\text{Trim up: } R_T = \frac{a R_2}{R_2 - a} - R_3 \quad a = \frac{V_{ref}}{V_{OUT} - V_{ref}} R_1$$

$$\text{Trim down: } R_T = \frac{a R_1}{R_1 - a} - R_3 \quad a = \frac{V_{OUT} - V_{ref}}{V_{ref}} R_2$$

MU30H Series

30W, Wide 4:1 Input Range, 1.5KV Isolation, DIP2"X1" Package DC/DC Converters

Mechanical Specifications

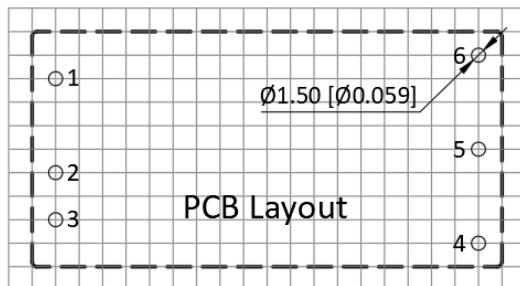
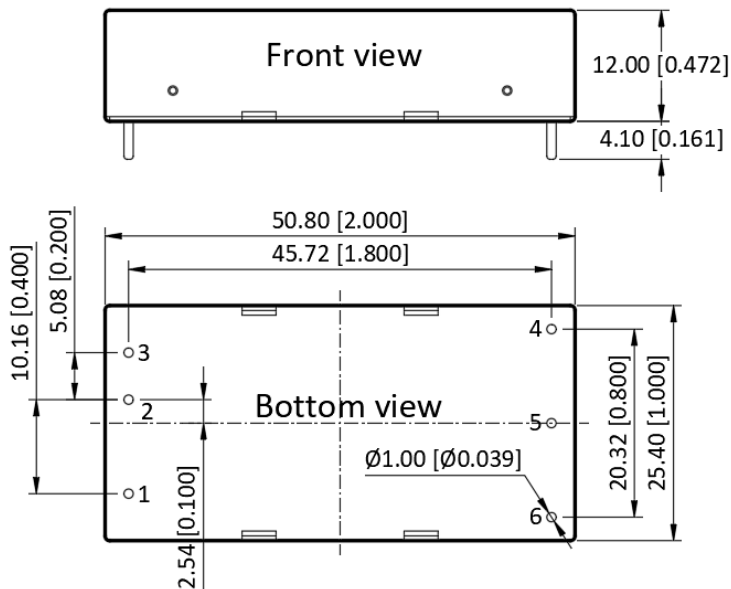

Pin Definition

Pin #	Single Out	Dual Out
1	Ctrl	Ctrl
2	GND	GND
3	V _{IN}	V _{IN}
4	+V _{OUT}	+V _{OUT}
5	0V	0V
6	Trim	-V _{OUT}

* Unless otherwise specified unit: mm [inch]

* General tolerance: ± 0.50 [± 0.020]

* Pin thickness: ± 0.10 [± 0.004]

* Footprint grid 2.54 x 2.54 mm

FAVOTEK LIMITED

#17 Canton Road, Tsim Sha Tsui, Kowloon, Hong Kong
 Tel: +852 8191 6662
 Eml: info@favotek.com

Favotek reserves the right to make changes to the product at any time without notice. Information provided by Favotek is believed to be accurate and reliable. However, no responsibility is assumed by Favotek for its use, nor for any infringements of patents or other rights of third parties which may result from its use.