

注：格亚电气有权对本文件内容进行技术变更或修改，恕不另行通知。对于采购订单，应以约定细节为准，对于本文件中可能存在的错误或可能缺少的信息，格亚电气不承担任何责任。

**GEYA 格亚电气**



**浙江格亚电气有限公司**  
ZHEJIANG GEYA ELECTRICAL CO.LTD.

地址：浙江省温州市北白象镇瑄头村滨江路91号  
电话：0577-62926966 手机：13567770207  
邮箱：sale@cngeya.com 网址：www.cngeya.com

**GEYA 格亚电气**  
一切为了用电安全

# 双电源综合目录

Dual Power Comprehensive Catalog



**励磁式双压簧**

励磁式双压簧专利结构  
提高接通分断能力

**单刀双掷拍合式**

采用单刀双掷拍合式触头结构，切换更迅速

**转换时间<20ms**

线圈励磁驱动，  
转换时间<1s  
触头转换时间<20ms

**双安装方式**

导轨/螺丝  
双安装方式

**独立灭弧室**

配备独立灭弧室，  
有效快速灭弧



双电源转换开关  
国际领先 小而不凡

# G2R

## 双电源自动转换开关

Dual power automatic transfer switch

配电设备的小型化意味着配电柜内安装密度的提升和柜体数量的有效优化可以有效降低建筑成本G2R系列智能自动转换开关采用极致体积优化设计并依然具备优异的电气、机械性能可安装在传统的PZ30柜内部。

The miniaturization of distribution equipment means that the increase in installation density inside the distribution cabinet and the effective optimization of the number of cabinets can effectively reduce building costs. The G2R series intelligent automatic transfer switch adopts extreme volume optimization design and still has excellent electrical and mechanical performance, which can be installed inside traditional PZ30 cabinets.





## G2R 双电源自动转换开关 Automatic transfer switch

G2R-63双电源自动转换开关属于PC级不频繁切换开关，两工位设计（常用A工作，备用B工作），适用于交流50-60Hz，额定电流6A-63A的交流电系统。双电源自动转换开关的主要作用是当用户主电源（常用电源A）发生异常后，产品自动投切至备用电源（备用电源b）继续工作（切换速度 < 50毫秒），有效解决用户因断电引起的困扰。

G2R-63 automatic transfer switch is a PC class infrequent change-over switch, with two-station design (commonly used for A and standby for B), suitable for AC systems with AC 50-60Hz and rated current 6A-63A. The main function of the automatic transfer switch is when the main power (common power supply A) fails, the ATS will automatically switch to the backup power (Backup power supply B) to continue working (switching speed < 50 milliseconds), which can effectively solve the troubles caused by power outages.

### 正常工作条件 Working Conditions

运行环境温度范围为-5°C~+40°C，且其24h内的平均温度值不超过+35°C，存储环境温度范围为-25°C~+55°C，短时间内(24h内)可达+70°C。

安装地点的海拔高度不超过2000m。

安装地点的空气相对湿度在周围空气温度为+40°C时不超过50%，在较低温度下可以有较高的相对湿度。例如：在最湿月的平均最低温度为+20°C时，该月的月平均最高相对湿度可达90%。对于温度变化而产生的凝露应采取适当的措施予以防止。

污染等级3级(有导电性污染，或由于凝露使干燥的非导电性污染变为导电性的)。ATS可以垂直或水平安装在柜体内，若有特殊安装要求需与我司联系。产品外壳防护等级为IP30。

过电压类别:主电路III类；控制和辅助回路II类。

The temperature range of the operating environment is -5°C~+40°C, and the average temperature within 24 hours shall be lower than +35°C, and the temperature range of the storage environment is -25°C~+55°C, which can be reached +70°C in a short time (within 24 hours)

The altitude of the installation site should be lower than 2000m.

The relative temperature at the installation site shall not exceed 50% when the ambient air temperature is +40°C. Higher relative humidity is possible at lower temperatures. For example: when the average minimum temperature of the wettest month is +20°C, the monthly average maximum relative humidity of that month can reach 90%. Appropriate measures should be taken to prevent condensation due to temperature changes.

Pollution level 3 (conductive pollution, or dry non-conductive pollution becomes conductive due to condensation). ATS can be installed vertically or horizontally in the cabinet, if there are special installation requirements, contact us.

The protection grade of ATS case is IP30.

Overvoltage category

Main circuit category III; control and auxiliary circuit category II.

### 产品型号及含义 Product model and meaning

G	2	R	—	63	□	□
企业代号 Company code	产品类别 Product Category	安装方式 Installation method		壳架等级 Case grade	极数 Pole	
浙江格亚电气 有限公司 ZHEJIANG GEYA ELECTRICAL CO.,LTD	PC级自动转换 开关(二工位) PC class automatic transfer switch (two stations)	导轨安装 Din-rail installation		63	2P/4P	额定工作电压 Rated working voltage: AC220V, AC110V  额定工作电流 Rated working current: 6A/10A/16A/20A/25A/ 32A/40A/50A/63A

### 主要技术参数 Technical Specification

	63								
额定工作电流Ie(A) Rated operating current Ie(A)	06A	10A	16A	20A	25A	32A	40A	50A	63A
额定绝缘电压UI Rated insulation voltage UI	690V								
额定冲击耐受电压Uimp Rated impulse withstand voltage Uimp	8kV								
额定工作电压Ue Rated working voltage Ue	AC220V/AC110V								
额定频率 Rated frequency	50/60Hz								
级别 Class	PC级别：可以接通和承载，同时不产生短路电流 PC class: can be switched on and loaded without generating short-circuit current								
极数 Pole number	2P				4P				
额定短路电流Iq Rated short-circuit current Iq	5kA								
短路保护装置(保险丝) Short circuit protection device (fuse)	RT16-00-63A								
额定冲击耐受电压 Rated impulse withstand voltage	8kV								
控制电路 Control circuit	额定控制电压Us:AC220V/110V,50/60Hz 正常工作条件:85%Us-110%Us Rated control voltage Us: AC220V/110V, 50/60Hz Normal working conditions: 85%Us-110%Us								
辅助电路 Auxiliary circuit	AC220V/110V 50/60Hz Ie=5A								
过压/欠压保护范围 Overvoltage/undervoltage protection range	220V/50Hz 欠压值: 175V 恢复值: 195V.过压值: 260V 恢复值: 240V (±5V) 110V/50Hz 欠压值: 85V 恢复值: 95V. 过压值: 145V 恢复值: 130 (±5V) 220V/50Hz Undervoltage value: 175V Recovery value: 195V. Overvoltage value: 260V Recovery value: 240V (±5V) 110V/50Hz Undervoltage value: 85V Recovery value: 95V. Overvoltage value: 145V Recovery value: 130 (±5V)								
机械寿命 Mechanical life	≥8000次 ≥8000 times								
电气寿命 Electrical life	≥1500次 ≥1500 times								
使用类别 Usage category	AC-31B								

**注意事项** Notes

手动/自动操作可以确保电气操作的开和关性能，但是在手动操作中，由于操作员的开/关速度不同，因此无法保证。在手动操作中，可能会发生过多的银合金损失。因此，只有在切断所有电源以检查和维护操作系统及联系信息后，才能将选择器开关拉到手动位置。通常，请将选择器开关拉到电动位置。需要手动操作时，将选择器开关拉到手动位置。手动操作完成后，将选择器开关从手动位置拉到自动位置。双电源属于应急切换开关，切换速度和频率不宜过高。如果有测试需要，切换时间不能小于1分钟一次的频率。双电源开关内置弹簧互锁机构，严禁非专业人员在通电情况下手动切换开关，错误的操作会导致触头损耗，导致使用寿命下降。

Manual/automatic operation can ensure the opening and closing performance of electrical operation, but in manual operation, there is no guarantee due to the different opening/closing speeds of the operators. In manual operation, there's possible for excessive silver alloy loss. Therefore, the selector switch should only be pulled to the manual position after all power has been cut off for inspection and maintenance of the operating system and contact information. Normally, pull the selector switch to the electric position. When manual operation is required, pull the selector switch to the manual position. After manual operation is complete, pull the selector switch from the manual position to the automatic position. The dual power supply belongs to the emergency switching switch, and the switching speed and frequency should not be too high. If testing is required, the switching time should not be less than a frequency of once every minute. The dual power switch is equipped with a spring interlocking mechanism, and it is strictly prohibited for non professionals to manually switch the switch when powered on. Incorrect operation can cause contact loss and reduce service life.

**安装** Installation

ATS 的安装与调试中的各项工作应由专业人士和了解该开关设备的人员进行，工作中必须考虑相应的保护和预防措施。开关主回路的接线方式必须使引线不受任何压力或强力作用。安装调试前应先查验开关有无损坏或其它任何有危害性的环境影响，同时应检查可能在运输中造成的线头松动，清除脏污，尤其是绝缘件表面的脏污，这些脏污可能是由于在运输过程中透过包装材料或在存储过程中造成的。在连接一次回路时应注意两路电源的相序一致，连接二次回路时应严格按照该说明书中列出的接线图，同时注意控制电源电压等级；开关安装时必须有良好的接地。考虑到人身安全与开关切换的快速性，调试手柄仅作调试用，用户切勿用调试手柄带负荷操作。调试时应先用手柄操作开关，若无异常，再用手动按钮电动操作，无异常后进行正式运行。

The installation and debugging of ATS should be carried out by professionals and personnel familiar with the switchgear, and corresponding protection and preventive measures must be considered during the work. The wiring method of the main circuit of the switch must ensure that the leads are not subjected to any pressure or strong force. Before installation and debugging, the switch should be checked for any damage or other harmful environmental effects. At the same time, any loose wire heads that may be caused during transportation should be checked to remove dirt, especially on the surface of insulation parts. These dirt may be caused by passing through packaging materials during transportation or during storage. When connecting the primary circuit, attention should be paid to ensuring that the phase sequence of the two power sources is consistent. When connecting the secondary circuit, strict adherence to the wiring diagram listed in this manual should be followed, and attention should be paid to controlling the voltage level of the power supply; The switch must be installed with good grounding. Considering personal safety and the speed of switch switching, the debugging handle is only for trial use. Users should not use the debugging handle to operate under load. When debugging, the switch should be operated with a handle first. If there are no abnormalities, the manual button should be used for electric operation. After there are no abnormalities, the official operation can be carried out.

**维护** Maintenance

维护和检查应由专业人员进行。切断所有电源之前。为确保ATS的良好性能，应在使用后的6个月内进行首次维护和检查。然后每年至少维护和检查一次。在恶劣的安装条件下，应增加维护和检查的频率。如果维护和检查项目失败，请清除灰尘。 b: 请检查电触头部件是否变形和损坏，并清除表面。c: 及其周围的金属颗粒和烧焦。接触表面上的锈蚀，酸化和灰尘可能会导致接触不良，因此请执行一些手动操作并测量必要的接触电阻。d: 如果ATS潮湿或长时间空置，请在打开电源之前将其干燥。清除灰尘后，使用500V兆欧表测量正常电源和交流电源的绝缘电阻。负载侧和两极，包括绝缘电阻，在使用带电部件和金属板时，绝缘电阻不应小于10MQ。苯丙胺类兴奋剂应与正常工作条件在相同的环境中存放，并采取防尘，防潮和防撞措施。

Maintenance and inspection should be carried out by professionals. In order to ensure the good performance of the ATS, the first maintenance and inspection should be carried out within 6 months after use. Then do the maintenance and inspection at least once a year. In harsh installation conditions, the frequency of maintenance and inspection should be increased. If the maintenance and inspection items fail, please remove the dust. b: Please check whether the electrical contact parts are deformed and damaged, and clean the surface. c: metal particles and burnt around it. Rust, acidification and dust on the contact surfaces can cause poor contact, so do some manual work and measure the necessary contact resistance. d: If the ATS is wet or left unused for a long time, please dry it before turning on the power. After removing the dust, use a 500V megohmmeter to measure the insulation resistance of the normal power supply and the AC power supply. The load side and two poles, including the insulation resistance, when using live parts and metal plates, the insulation resistance should not be less than 10MQ.

**接线说明** Wiring instructions

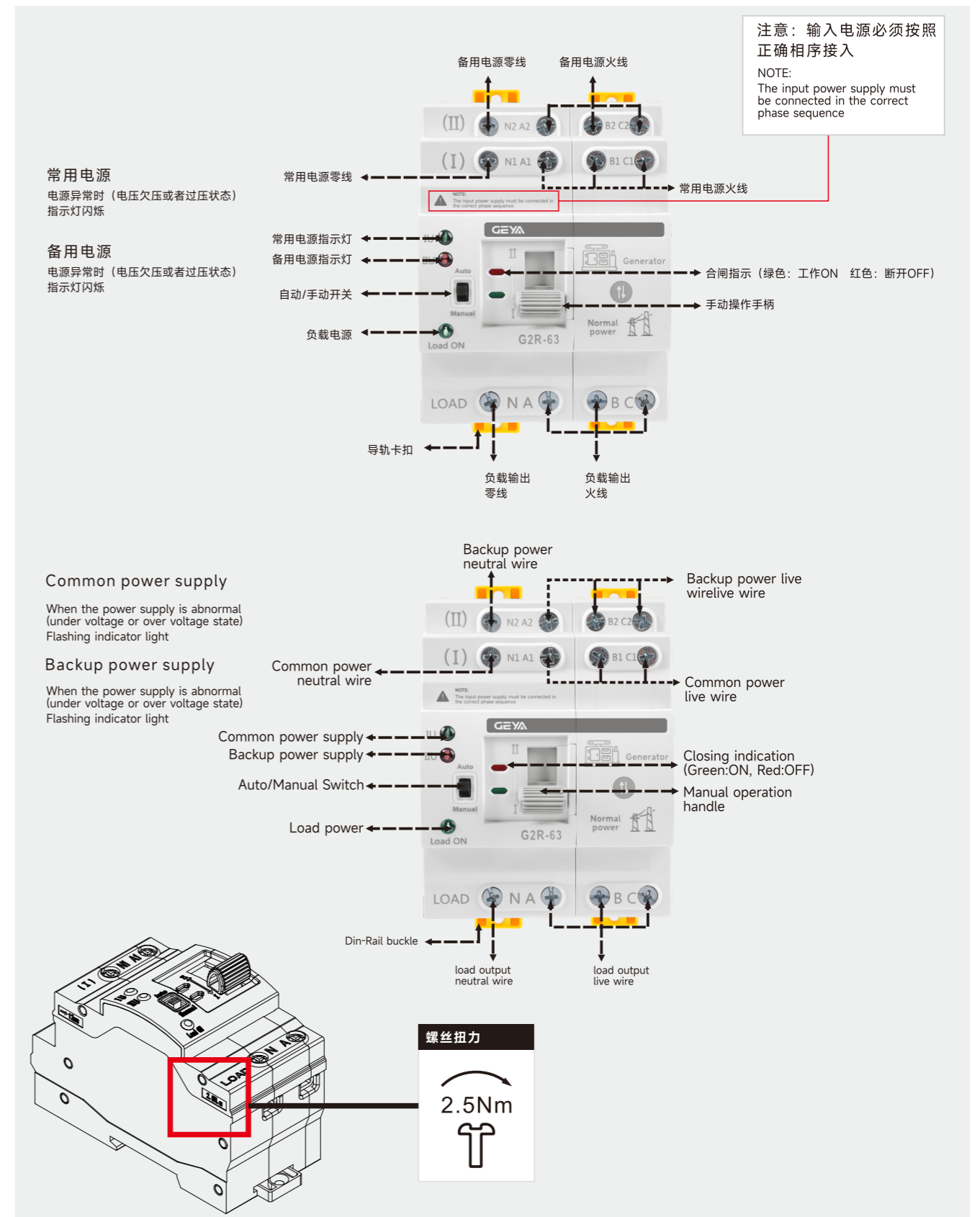

产品尺寸 Size

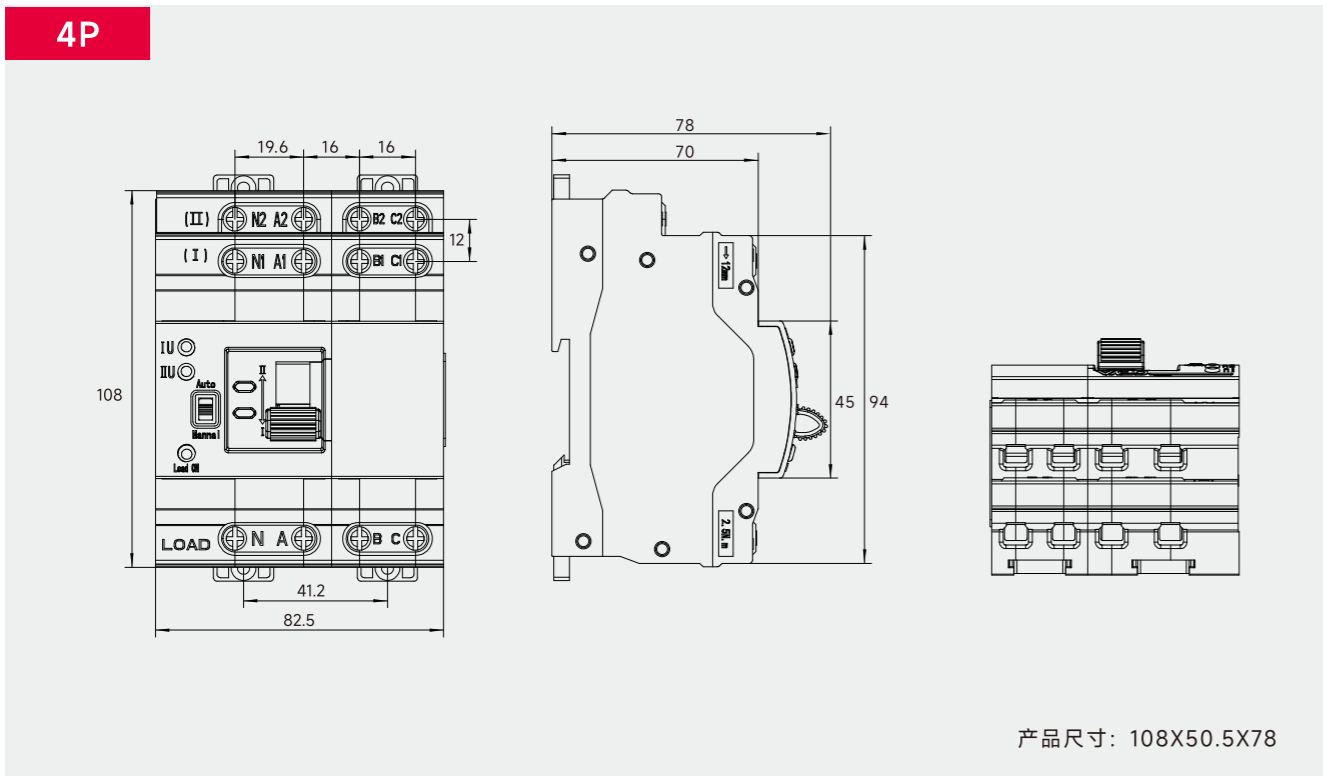
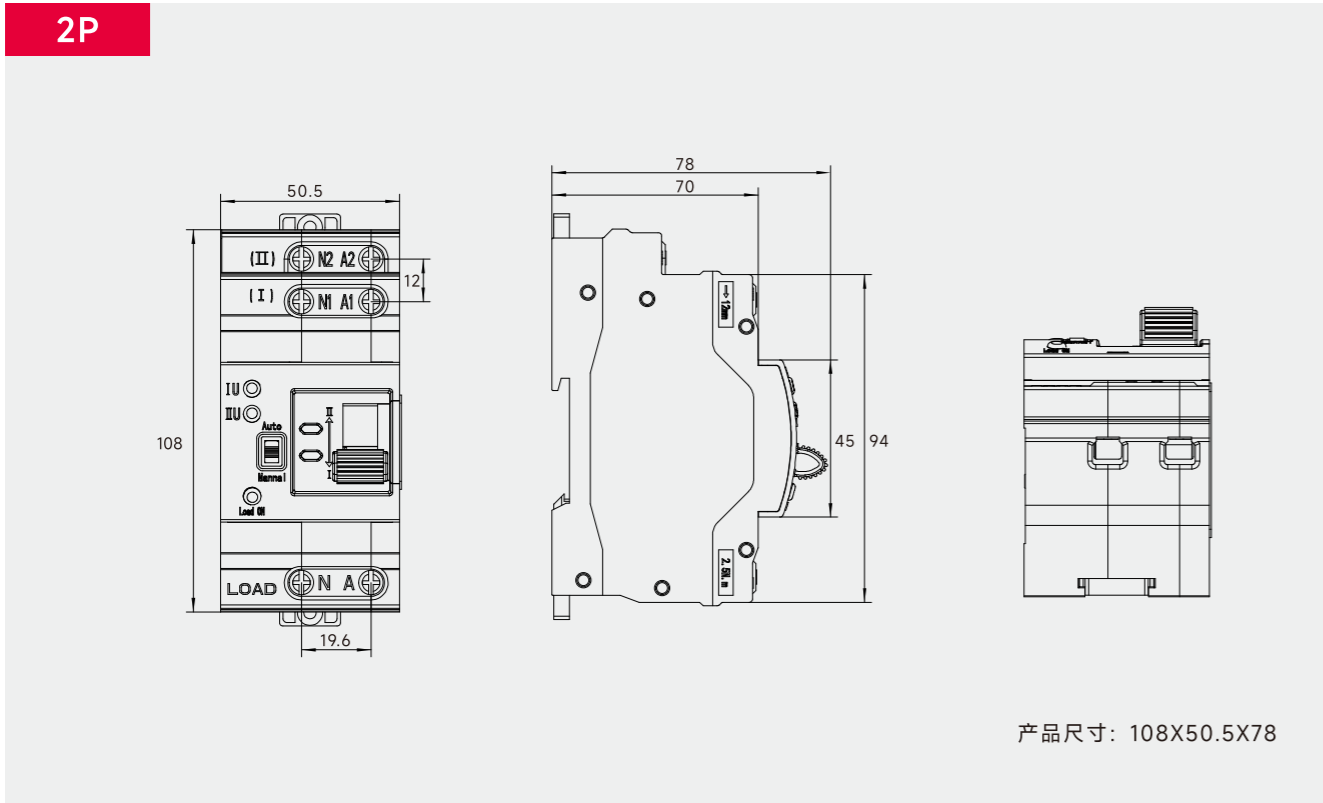

原理图 schematic diagram

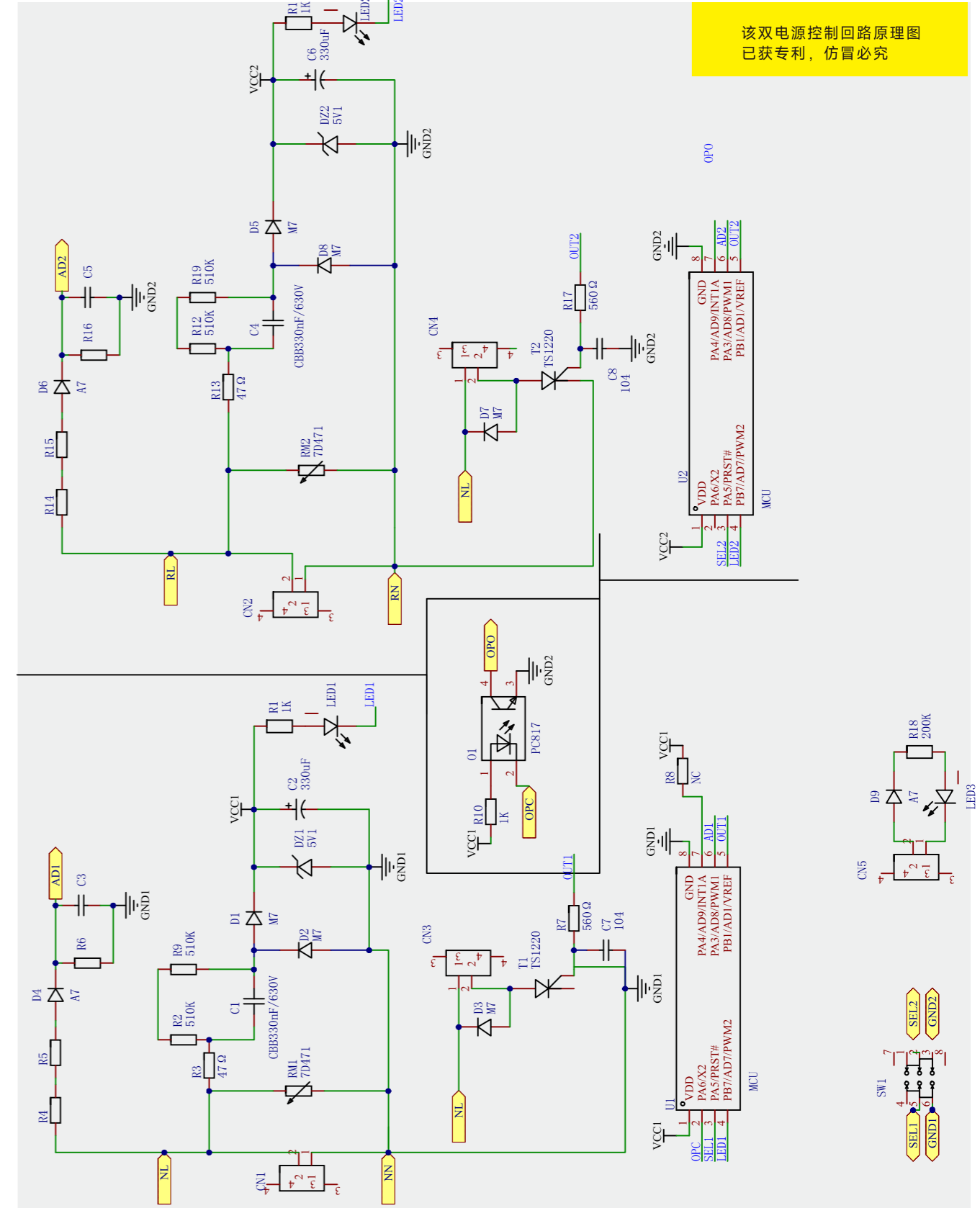

**应用场景** Application scenarios

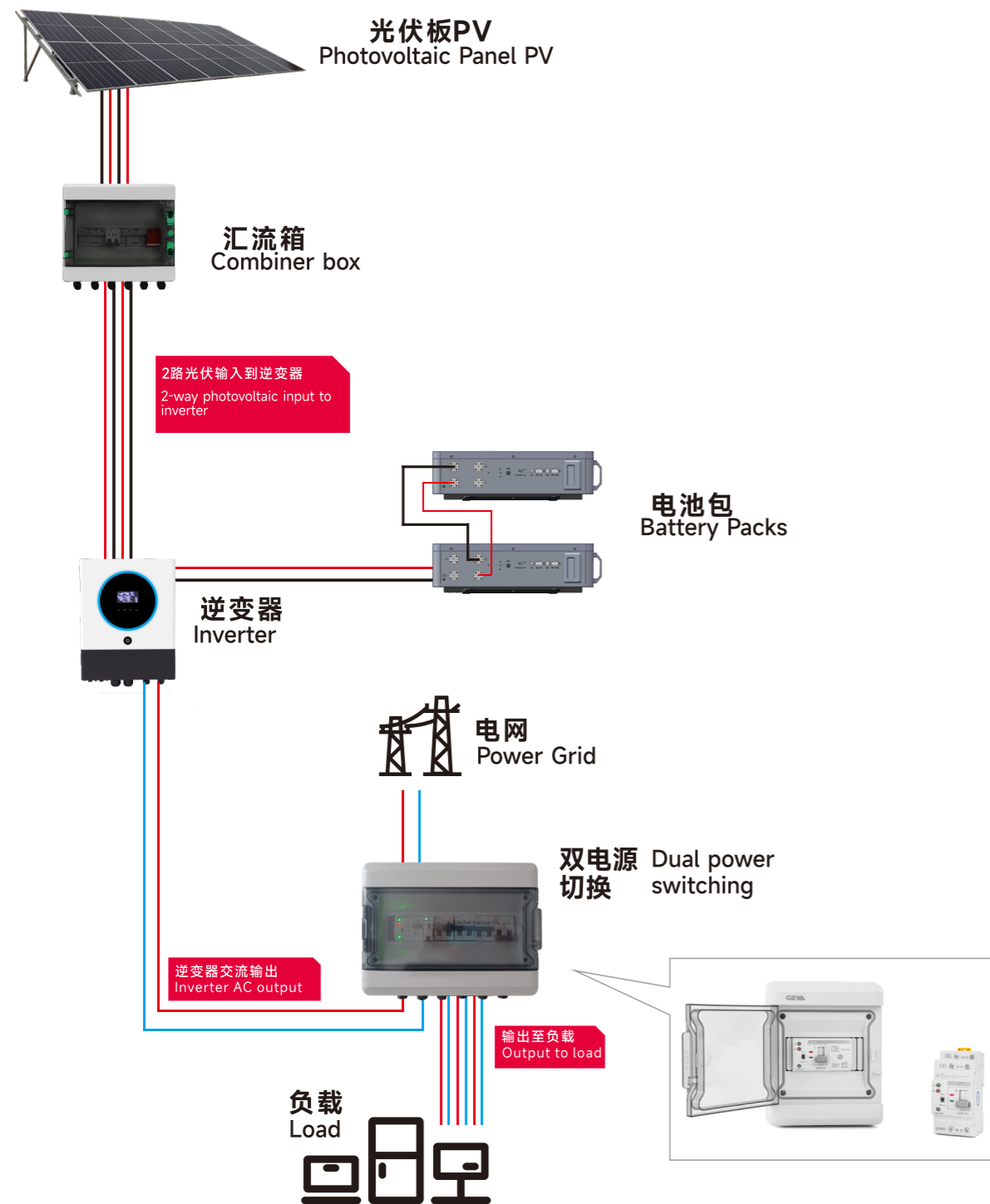

**可安装配电箱内**

Can be installed inside the distribution box

