

Data Sheet

Customer: _____

Product: Ceramic Disc Capacitor - Class I _____

Type : T _____

Issued Date: 18-Jan.-2023 _____

Edition: Ver. 2 _____

Record of change

Date	Ver.	Description	Page
30-Dec.-2016	1		
18-Jan.-2023	2	Revised Part No.	

HITANO ENTERPRISE CORP.

7F-7, No. 3, Wu Chuan 1st Road, New Taipei Industrial Park,

New Taipei City, TAIWAN, R.O.C.

Tel: +886 2 2299 1331 (Rep.)

Fax: +886 2 2298 2466, 2298 2969

Prepared by	Checked by	Approved by	Accepted by (customer)
18-Jan.-2023	18-Jan.-2023	18-Jan.-2023	
Hwa Wu	Andy Hsu	Arthur Su	

FEATURES

- ※ Linear temperature coefficient of capacitance.
- ※ High stability of capacitance
- ※ Low loss at wide range of frequency

Part No. Designation

Example	T	N	050	101	K	-	L	5	1	5	B
	(1)	(2)	(3)	(4)	(5)		(6)	(7)	(8)	(9)	(10)

1. Class I —Type‘T’

2. Temperature Coefficient (Ref. Fig 1)

Code	PPM/°C	T.C.	EIA Code
N	0±60	NP0	COH
S	+350~-1,000	P350~N1000	S2L

3. Rated Voltage (D.C.)

Code	Voltage	Code	Voltage
050	50V	500	500V
063	63V	630	630V
100	100V	1K0	1000V

4. Rated Capacitance

Code	Cap. (PF)	Code	Cap. (PF)
010	1PF	390	39PF
1R5	1.5PF	470	47PF
2R2	2.2PF	560	56PF
3R3	3.3PF	680	68PF
3R9	3.9PF	820	82PF
4R7	4.7PF	101	100PF
5R6	5.6PF	121	120PF
6R8	6.8PF	151	150PF
8R2	8.2PF	181	180PF
100	10PF	221	220PF
120	12PF	271	270PF
150	15PF	331	330PF
180	18PF	391	390PF
220	22PF	471	470PF
270	27PF	561	560PF
330	33PF	681	680PF

5. Tolerance On Rated Capacitance

Code	Tolerance	Rated Cap. (PF)
C	±0.25PF	Under 10pF
D	±0.5PF	
J	±5%	From 10pF to 680pF
K	±10%	

6. Lead Shape. (Ref. Fig. 3.)

Code	Type	
K	Bulk	Short Kink
S		Short Straight
L		Long Straight
A	Taping	Inside Kink
B		Straight

7. Lead Spacing. (F)

Code	Dimension. (mm)		
	K	S	L
2	---	2.5±0.8	2.5±0.8
5	5.0±0.8	5.0±0.8	5.0±0.8
6	---	6.3±0.8	6.3±0.8
7	---	7.5±0.8	7.5±0.8
0	9.5±0.8	9.5±0.8	9.5±0.8

8. Lead Length. (L)

Code	Dimension (mm)		
	K	S	L
5	5.0±0.8	5.0±0.8	
6	6.0±0.8	6.0±0.8	
0	10.0±0.8	10.0±0.8	
1	---	---	25min

9. Lead Wire. (d)

Code	Dia (φ mm)	Rated Voltage (D.C.)
5	0.5±0.05	50V~500V
6	0.6±0.05	1KV

* Taping type lead dia. 0.6mm only.

10. Package

Code	Package	Q'ty
B	Bulk	1000pcs
A	Ammo Pack	2000pcs
R	Tape & Reel	2500pcs

Fig. 1B (P350-N1000)

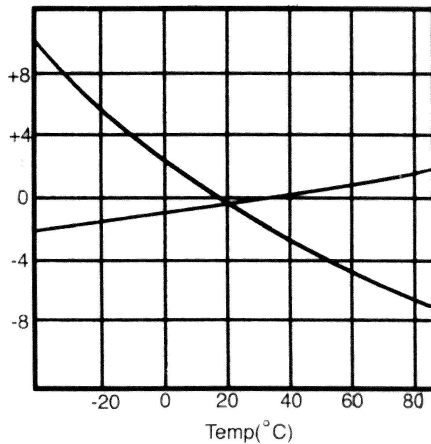
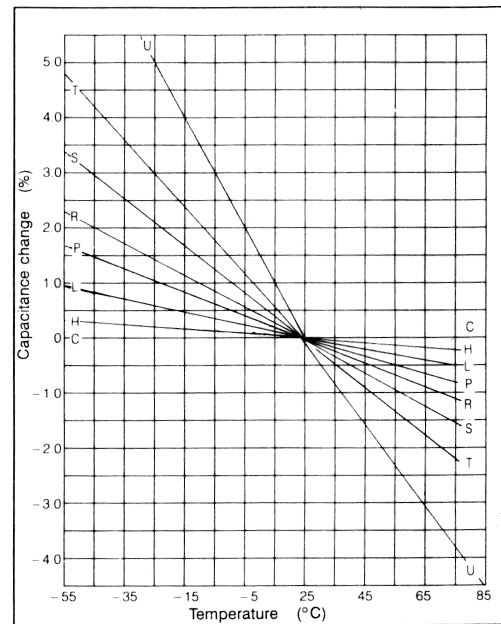

Fig. 1A(T. C. PPM/°C)



Dimension & Capacitance Range

Dia.(D) max	Dimension (mm)			Capacitance Range (pF)					
	Lead Spacing (F)			50 ~ 100V		500 ~ 630V		1KV	
	K	S	L	N	S	N	S	N	S
5.5				1 - 47	1 - 150	1 - 27	1 - 68	1 - 27	1 - 68
6.5				56 - 82	151 - 220	28 - 39	69 - 100	28 - 39	69 - 100
7.5	5.0±0.8	2.5±0.8	2.5±0.8	100 - 120	221 - 330	40 - 68	101 - 180	40 - 68	101 - 150
8.5	to	to	to	121 - 150	331 - 470	69 - 82	181 - 220	69 - 82	151 - 270
9.5	10.0±0.8	10.0±0.8	10.0±0.8	151 - 200	471 - 680	83 - 120	221 - 330	83 - 120	271 - 300
10.5				201 - 270	681 - 820	---	331 - 470	---	301 - 390
12.5				271 - 330	---	---	---	---	391 - 470

SPECIFICATION & TEST

No.	Item	Performance	Test Method
1.	Visual & Mechanical	To meet the specification	The product shall be inspected for visible evidence of defect
2.	Marking	To be clear and legible	Marking shall be tested with acetone.
3.	Voltage Proof (Between terminal)	No failure	2.5 times the rated voltage shall be applied for 1 to 5 sec. Charging and discharging current shall be limited to 50mA max
4.	Insulation resistance	10,000MΩ min	Shall be measured 1 minute after with rated voltage
5.	Capacitance	To be within the specified tolerance	Test frequency :1MHz ±100Hz Test voltage shall not exceed 5Vrms at 25±2°C
6.	Q Value	C≤30PF Q≥400+20*C. C>30PF Q≥1000.	Same condition as above (Item 5)
7.	Temperature Coefficient	To be within the specification	T.C. shall be calculated by the following formula: PPM/°C = [C(t1)-C(t2)/Ct1(t2-t1)]x10 ⁶ Ct2 = capacitance at t2 Ct1 = capacitance at t1 T2 = 85 ± 3°C T1 = 25± 2°C

Lead Shape (Fig. 3)

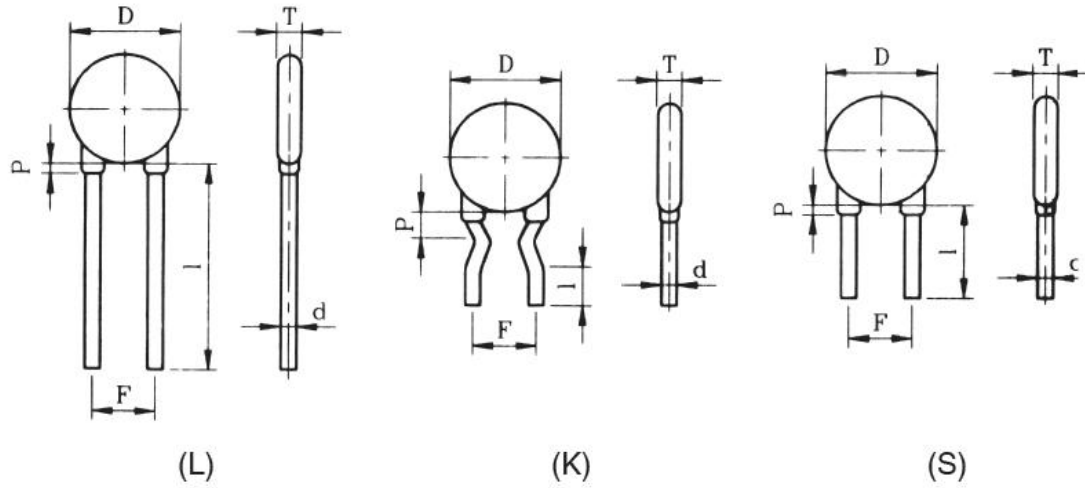

Taping Specification

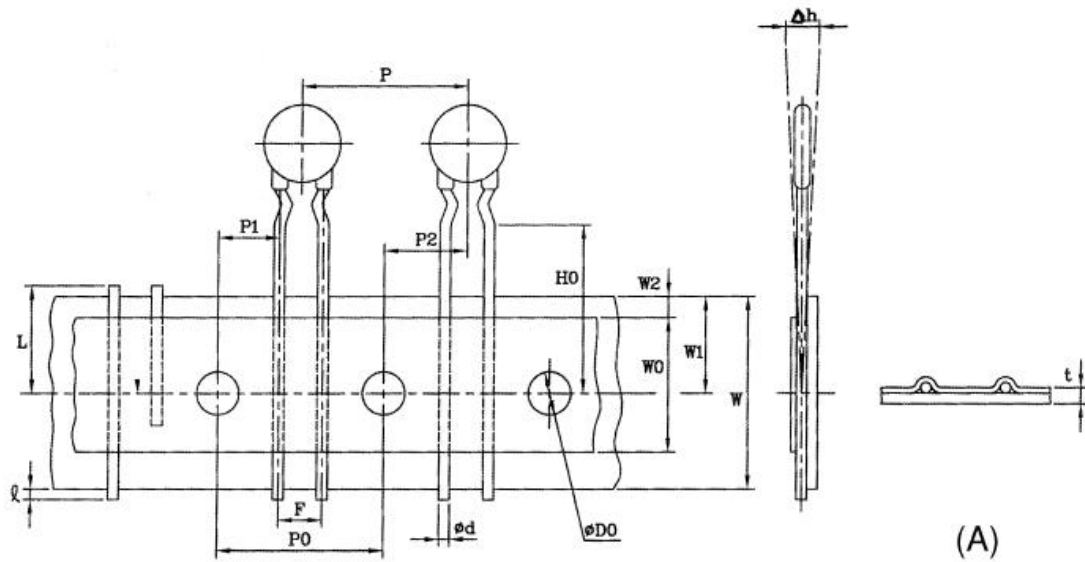

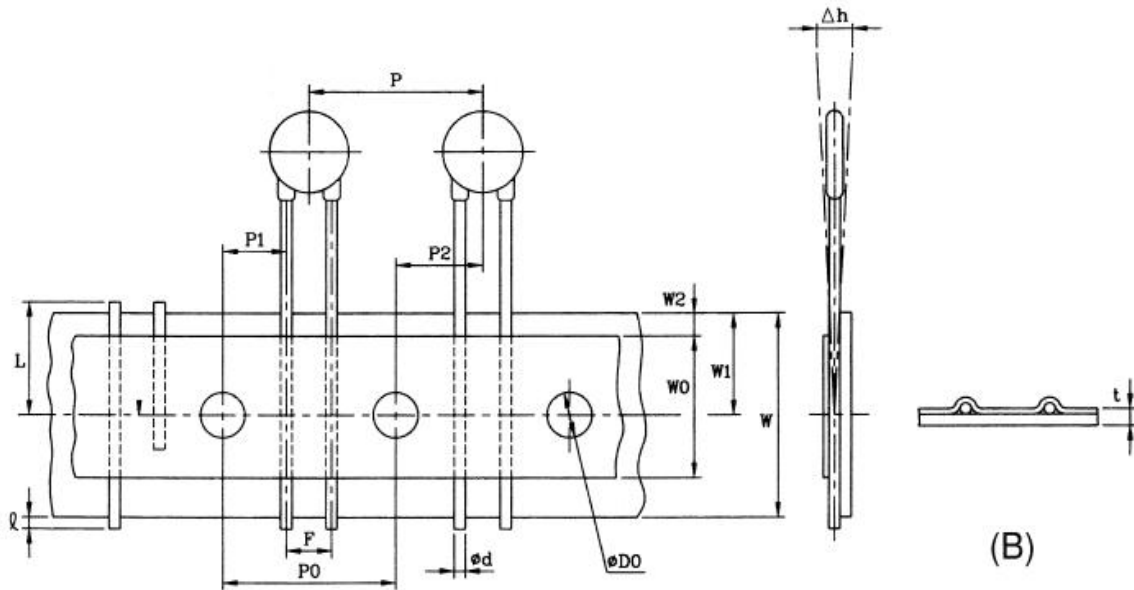

Symbol	P	P ₀	P ₁	P ₂	ϕd	F	Δh	W	W ₀	W ₁	W ₂	D ₀	t	L	H	H ₀
Dimension	12.7	12.7	3.85	6.35	0.6	2.54 5.08 6.35 7.62	0	18	12.5	9	3	4	0.7	11	20.0 23.0	16.0 18.0
Tolerance	±1.0	±0.3	±0.7	±1.0	±0.05	+0.8 -0.2	±2	±0.5	Min	+0.75 -0.5	Max	±0.3	±0.2	Max	+1.5 -1.0	±0.5